

 **TEREX**® | DEMAG



AC 200-1 | All Terrain Crane 240 t Lifting Capacity



AC 200-1

ALL TERRAIN CRANE

MUNNA CONSTRUCTION COMPANY PVT. LTD.

Office Address: Munna Construction Co. Pvt. Ltd. , 277 Shree Balajee Bhawan, Road no 1, Hill View Colony, Dimna, Mango, Jamshedpur, Jharkhand 831018.

Email: info@munnaconstruction.com; mccpl.bsl@gmail.com

Phone: +91 9431735332;

Website: www.munnaconstruction.com

AC 200-1
HIGHLIGHTS

- ▶ Shortest 200-tonner on 5 axles with 41.3 ft carrier length
- ▶ 7-section 223 ft boom with Unimec telescoping and pinning system giving unequalled 328.1 ft combined boom-and-jib length with the 108.3 ft boom extension fitted
- ▶ Speed-dependent rear axle steering for increased manoeuvrability and driving stability
- ▶ Innovative Demag IC-1 crane control system with touchscreen
- ▶ Carrier with modified axle arrangement available as an option

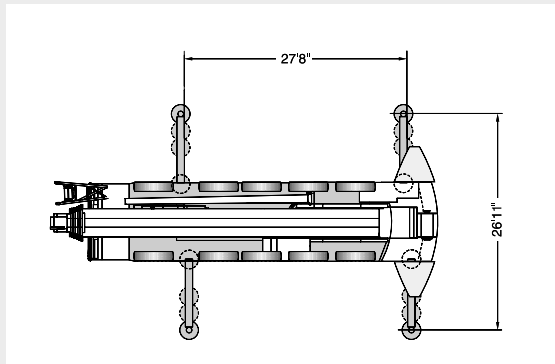
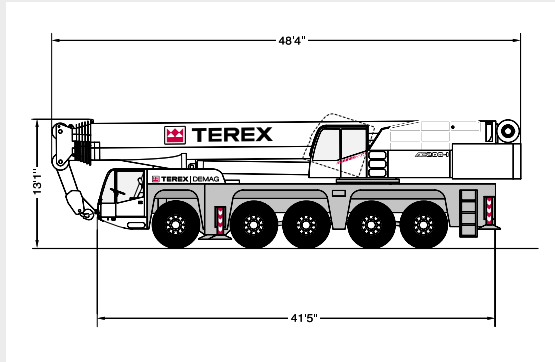
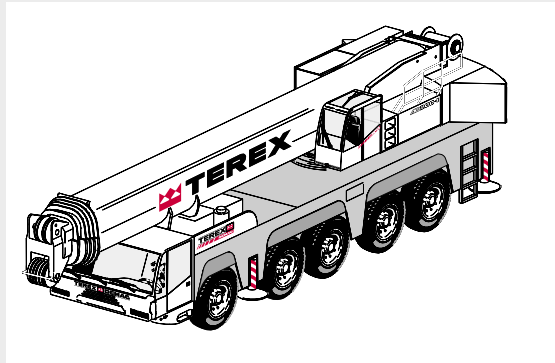

CONTENTS

Page:

Specifications

Dimensions	4
Axle weight with dolly	7
Specifications	8

1

Main boom

Working ranges	9
Lifting capacities	10

2

Main boom extension

Working ranges	14
Lifting capacities	15
Working ranges	19

3

Technical description

Carrier · Superstructure · Optional equipment	20
---	----

4

DIMENSIONS

AC 200-1

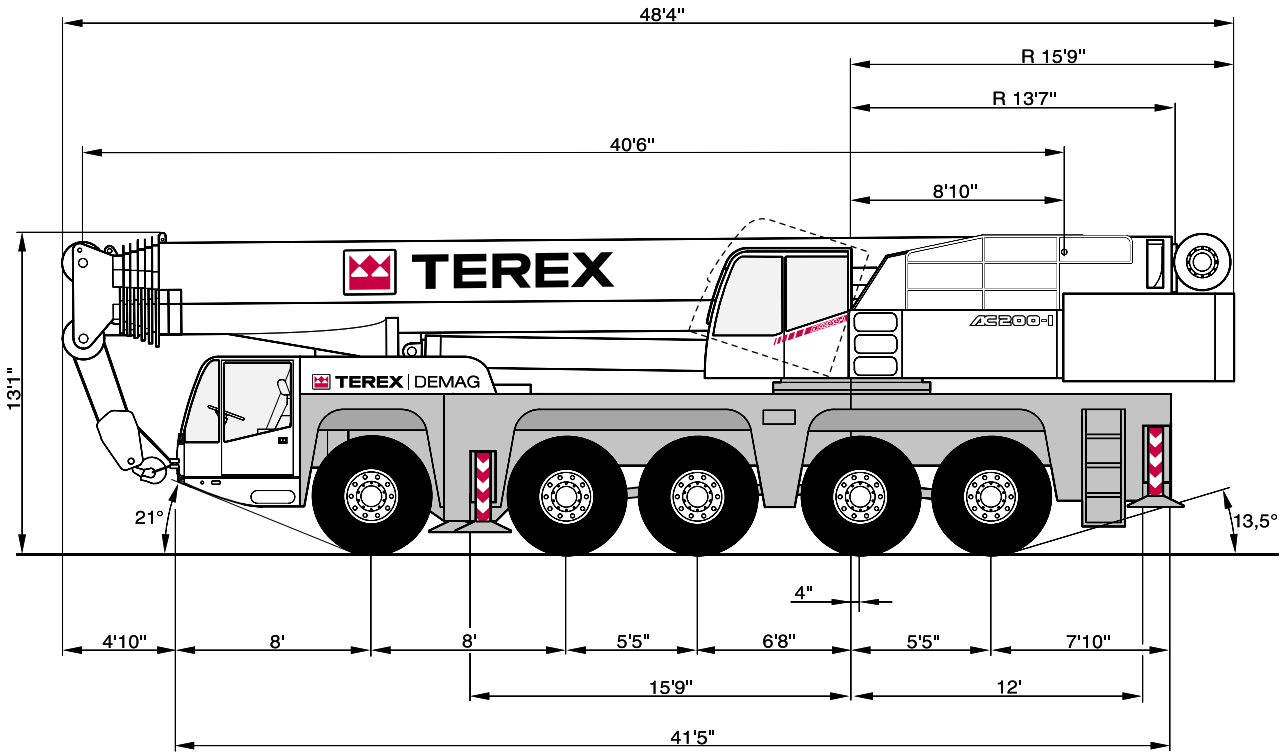

AC 200-1 P

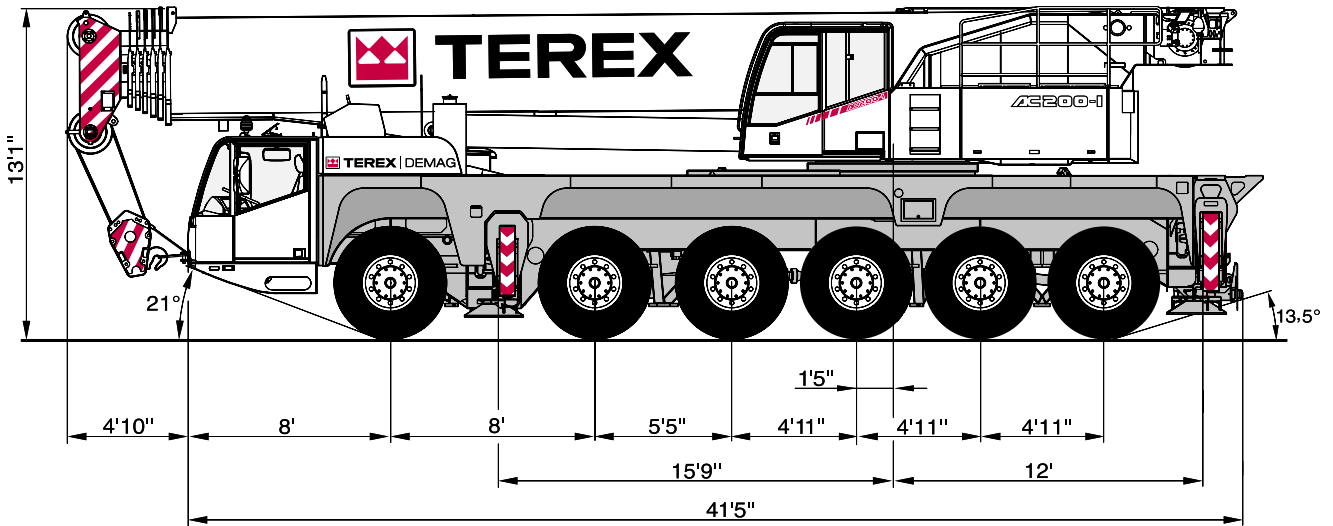

DIMENSIONS

AC 200-1 TP

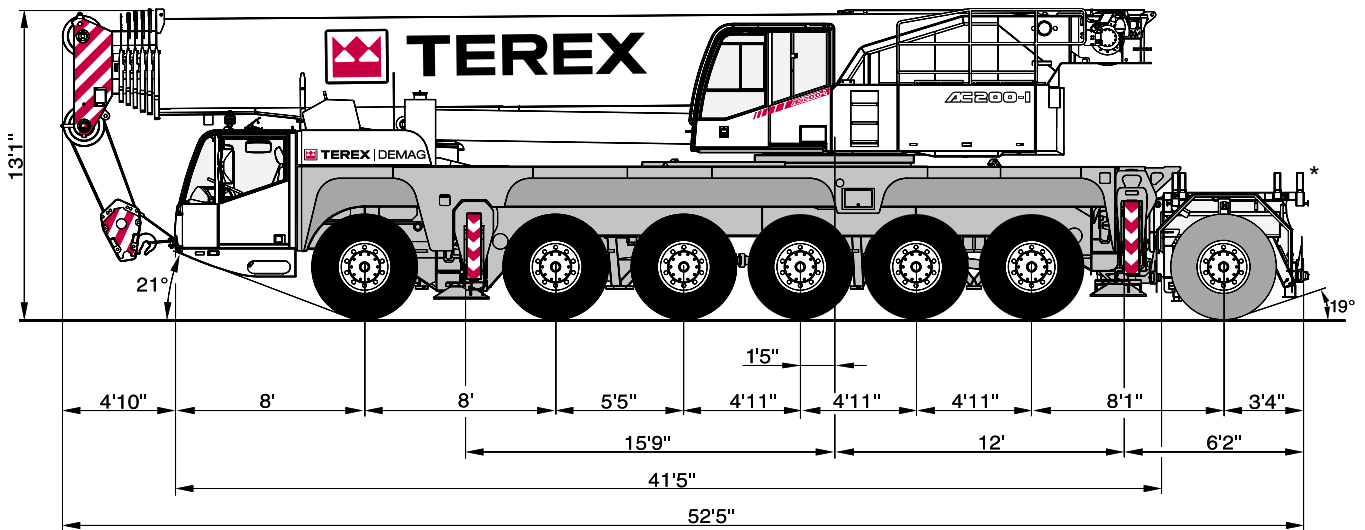

* with special attachment

OPTION: WITH MODULAR AXLE

Selection of configurations

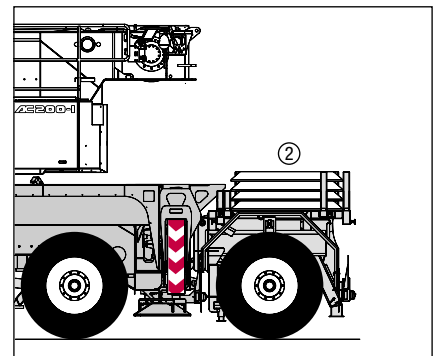
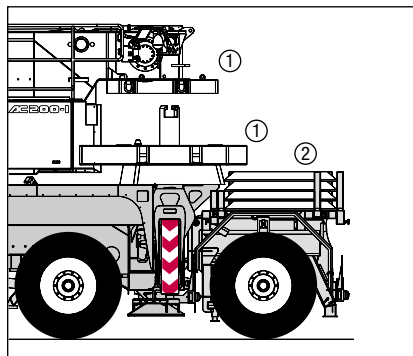
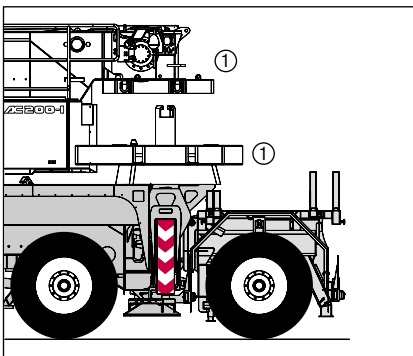

① Additional counterweight

② Base plates

DIMENSIONS

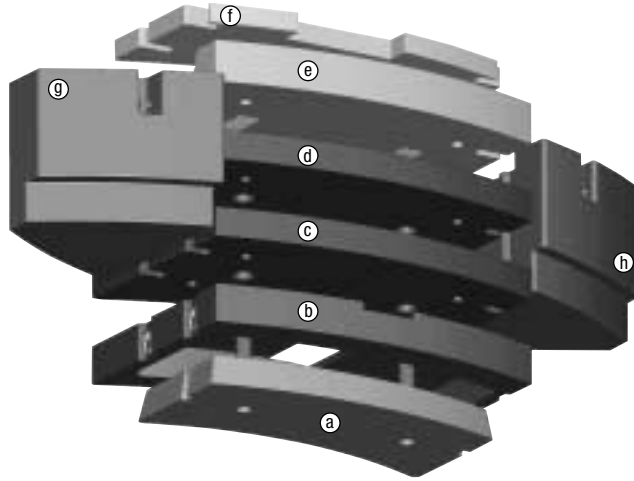

	(a) 12,600 lb	(b) 16,100 lb	(c) 19,800 lb	(d) 19,800 lb	(e) 20,100 lb	(f) 7,100 lb	(g) 28,200 lb	(h) 28,200 lb
19,600 lb	X					X		
28,700 lb	X	X						
32,600 lb	X		X					
35,900 lb	X	X				X		
39,700 lb	X		X			X		
48,700 lb	X	X	X					
55,800 lb	X	X	X			X		
68,600 lb	X	X	X	X				
75,800 lb	X	X	X	X		X		
88,600 lb	X	X	X	X	X			
95,700 lb	X	X	X	X	X	X		
132,100 lb	X	X	X	X		X	X	X
152,100 lb	X	X	X	X	X	X	X	X

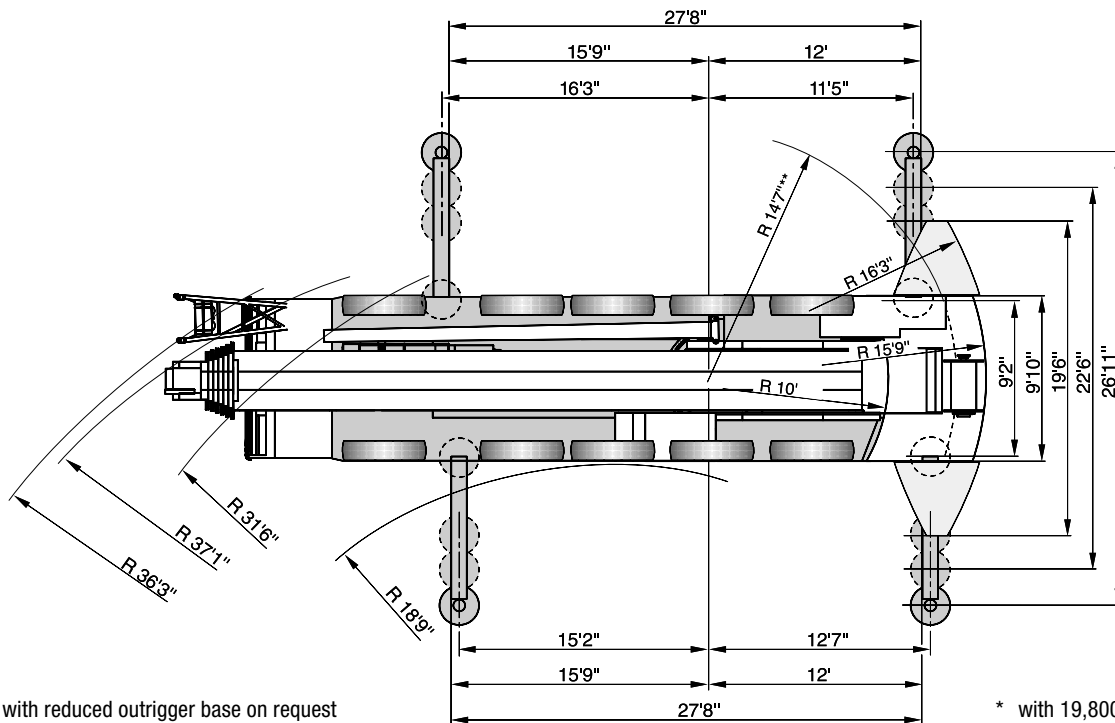
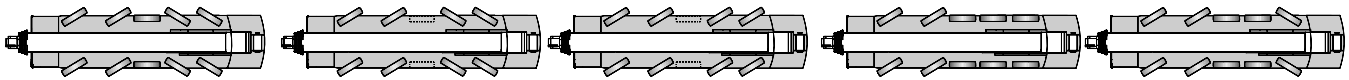

Duties with reduced outrigger base on request

* with 19,800 lb counterweight

ALL TERRAIN CRANE
AC 200-1

AXLE WEIGHT WITH DOLLY AC 200-1

CRANE CONFIGURATION

Drive	10 x 8 x 8
Tires	20.5 R 25
Outrigger front	
Outrigger rear	
Boom extended	3'3"
Hook block 3 sheaves	
2-axle boom dolly	5700 lb

AXLES

Axle	1	2	3	4	5	6	7	Total weight
Weight	21,935 lb	21,936 lb	18,781 lb	18,498 lb	18,287 lb	20,684 lb	20,684 lb	140,804 lb

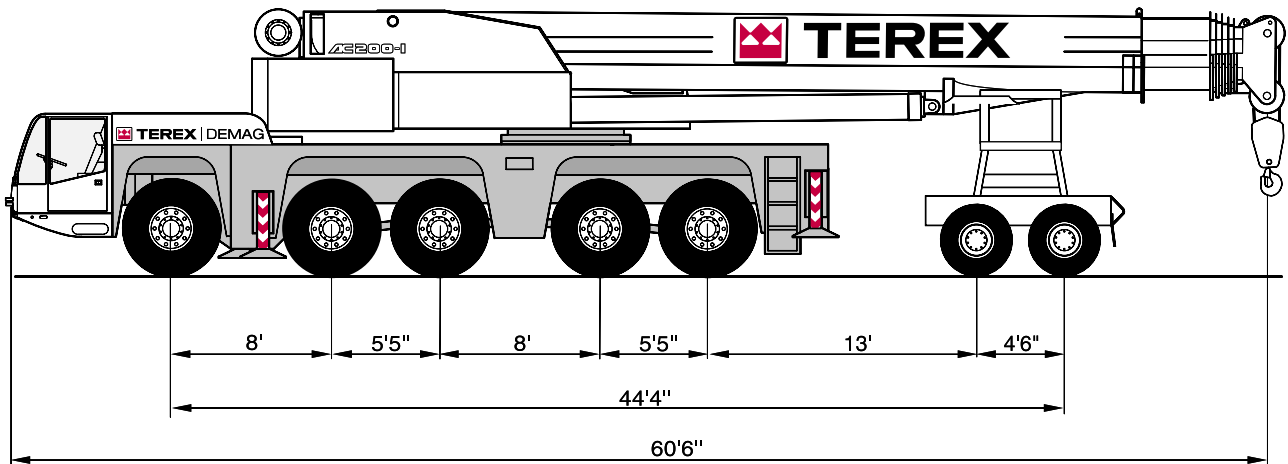

SPECIFICATIONS

AXLE LOADS

Basic machine with hook block

Axles 5 x 26,400 lb

Total weight 132,000 lb

WORKING SPEEDS (INFINITELY VARIABLE)

Mechanisms	Normal speed	High speed	Max. permissible line pull ¹⁾	Rope diameter / Rope length
Hoist I	147.6 ft/min	410 ft/min	22,000 lb	0,83" / 1132 ft
Hoist II	147.6 ft/min	410 ft/min	22,000 lb	0,83" / 1132 ft
Slewing				max. 1.3 1/min
Boom elevation				-1,5° - +82°

CARRIER PERFORMANCE

Travel speed 0 . . 53 mph

Gradeability max. 71 %

HOOK BLOCK / SINGLE LINE HOOK

Type	Possible load ¹⁾	Number of sheaves	Weight	„D“	Number of lines
200	324,500 lb	9	3,860 lb	9.8 ft	16
160	305,800 lb	7	3,310 lb	9.8 ft	15
125	228,600 lb	5	2,480 lb	9.8 ft	11
80	148,400 lb	3	1,870 lb	9.8 ft	7
32	64,800 lb	1	1,320 lb	8.9 ft	3
12,5	21,800 lb	Single line hook	770 lb	6.6 ft	1

Remarks

¹⁾ varies depending on national regulations

HA WORKING RANGES

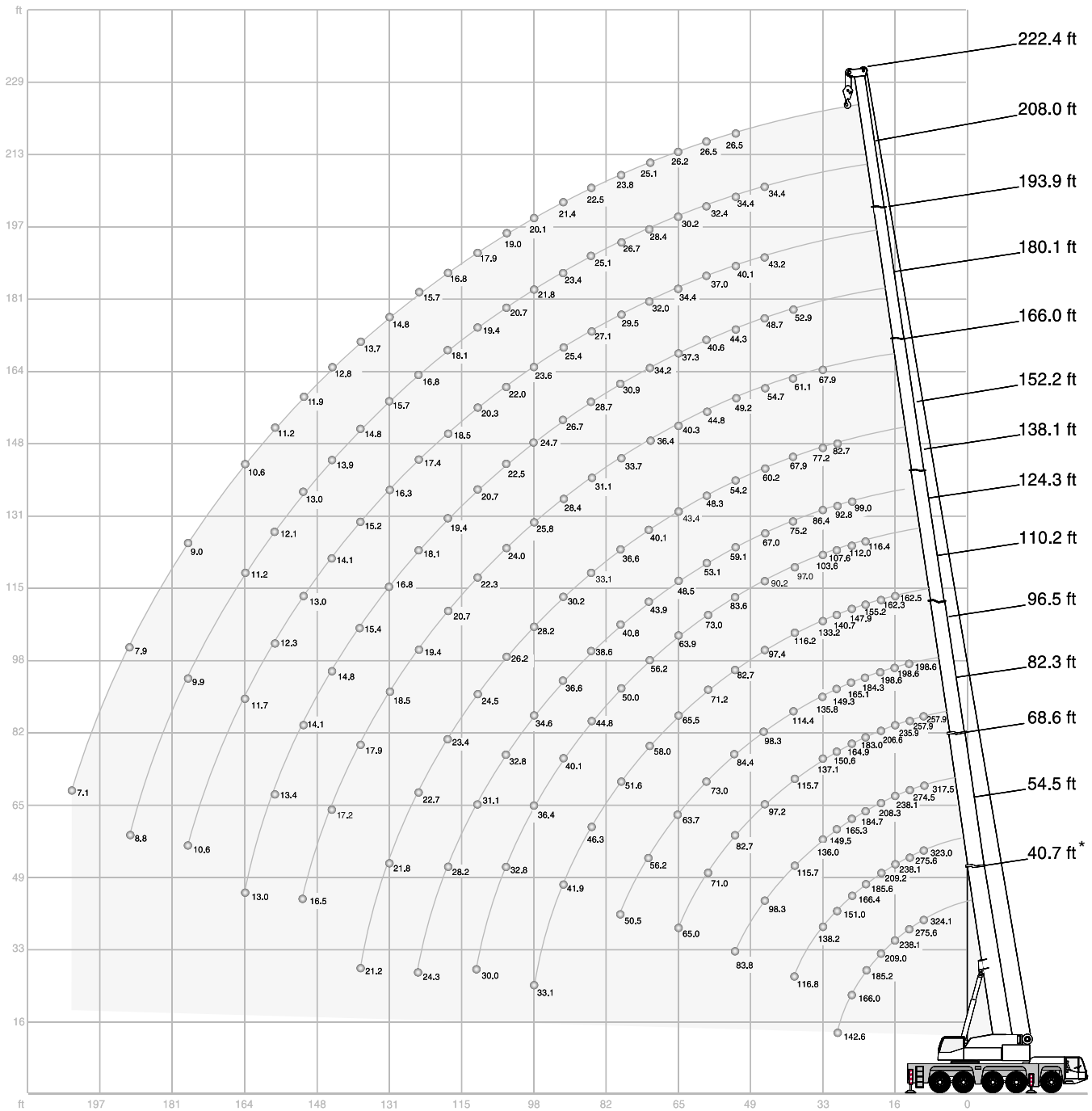

HA LIFTING CAPACITIES

152,100 lb

360°

85 %

Radius	Main boom															Radius	
	ft	40.7*	40.7	54.5	68.6	82.3	96.5	110.2	124.3	138.1	152.2	166.0	180.1	193.9	208.0		222.4
ft	1,000 lb															ft	
	480.0**	-	-	-	-	-	-	-	-	-	-	-	-	-	-	-	
10	324.1	324.1	323.0	317.5	257.9	-	-	-	-	-	-	-	-	-	-	-	10
11	323.0	297.6	298.7	296.5	257.9	-	-	-	-	-	-	-	-	-	-	-	11
13	299.8	275.6	275.6	274.5	257.9	198.6	-	-	-	-	-	-	-	-	-	-	13
15	280.0	255.7	255.7	255.7	253.5	198.6	-	-	-	-	-	-	-	-	-	-	15
16	262.4	238.1	238.1	238.1	235.9	198.6	162.5	-	-	-	-	-	-	-	-	-	16
19	230.4	209.0	209.2	208.3	206.6	198.6	162.3	-	-	-	-	-	-	-	-	-	19
23	203.3	185.2	185.6	184.7	183.0	184.3	155.2	116.4	-	-	-	-	-	-	-	-	23
26	175.7	166.0	166.4	165.3	164.9	165.1	147.9	112.0	99.0	-	-	-	-	-	-	-	26
29	142.6	142.6	151.0	149.5	150.6	149.3	140.7	107.6	92.8	82.7	-	-	-	-	-	-	29
33	-	-	138.2	136.0	137.1	135.8	133.2	103.6	86.4	77.2	67.9	-	-	-	-	-	33
39	-	-	116.8	115.7	115.7	114.4	116.2	97.0	75.2	67.9	61.1	52.9	-	-	-	-	39
46	-	-	-	98.3	97.2	98.3	97.4	90.2	67.0	60.2	54.7	48.7	43.2	34.4	-	-	46
52	-	-	-	83.8	82.7	84.4	82.7	83.6	59.1	54.2	49.2	44.3	40.1	34.4	26.5	-	52
59	-	-	-	-	71.0	73.0	71.2	73.0	53.1	48.3	44.8	40.6	37.0	32.4	26.5	-	59
65	-	-	-	-	65.0	63.7	65.5	63.9	48.5	43.4	40.3	37.3	34.4	30.2	26.2	-	65
72	-	-	-	-	-	56.2	58.0	56.2	43.9	40.1	36.4	34.2	32.0	28.4	25.1	-	72
79	-	-	-	-	-	50.5	51.6	50.0	40.8	36.6	33.7	30.9	29.5	26.7	23.8	-	79
85	-	-	-	-	-	-	46.3	44.8	38.6	33.1	31.1	28.7	27.1	25.1	22.5	-	85
92	-	-	-	-	-	-	41.9	40.1	36.6	30.2	28.4	26.7	25.4	23.4	21.4	-	92
98	-	-	-	-	-	-	33.1	36.4	34.6	28.2	25.8	24.7	23.6	21.8	20.1	-	98
105	-	-	-	-	-	-	-	32.8	32.8	26.2	24.0	22.5	22.0	20.7	19.0	-	105
111	-	-	-	-	-	-	-	30.0	31.1	24.5	22.3	20.7	20.3	19.4	17.9	-	111
118	-	-	-	-	-	-	-	-	28.2	23.4	20.7	19.4	18.5	18.1	16.8	-	118
124	-	-	-	-	-	-	-	-	24.3	22.7	19.4	18.1	17.4	16.8	15.7	-	124
131	-	-	-	-	-	-	-	-	-	21.8	18.5	16.8	16.3	15.7	14.8	-	131
138	-	-	-	-	-	-	-	-	-	21.2	17.9	15.4	15.2	14.8	13.7	-	138
144	-	-	-	-	-	-	-	-	-	-	17.2	14.8	14.1	13.9	12.8	-	144
151	-	-	-	-	-	-	-	-	-	-	16.5	14.1	13.0	13.0	11.9	-	151
157	-	-	-	-	-	-	-	-	-	-	-	13.4	12.3	12.1	11.2	-	157
164	-	-	-	-	-	-	-	-	-	-	-	13.0	11.7	11.2	10.6	-	164
177	-	-	-	-	-	-	-	-	-	-	-	-	10.6	9.9	9.0	-	177
190	-	-	-	-	-	-	-	-	-	-	-	-	-	8.8	7.9	-	190
203	-	-	-	-	-	-	-	-	-	-	-	-	-	-	7.1	-	203
216	-	-	-	-	-	-	-	-	-	-	-	-	-	-	-	-	216

Remarks

* over rear

** Exceptional load, additional measures required

HA LIFTING CAPACITIES

95,700 lb		360°														85 %
Radius	ft	Main boom														Radius
		40.7	54.5	68.6	82.3	96.5	110.2	124.3	138.1	152.2	166.0	180.1	193.9	208.0	222.4	
ft		1,000 lb														ft
10	318.6	318.6	316.4	257.9	-	-	-	-	-	-	-	-	-	-	-	10
11	292.1	292.1	291.0	257.9	-	-	-	-	-	-	-	-	-	-	-	11
13	269.0	269.0	267.9	257.9	198.6	-	-	-	-	-	-	-	-	-	-	13
15	249.1	249.1	248.0	246.9	198.6	-	-	-	-	-	-	-	-	-	-	15
16	231.5	231.5	230.4	229.3	198.6	162.5	-	-	-	-	-	-	-	-	-	16
19	202.6	202.8	201.9	200.4	198.6	162.3	-	-	-	-	-	-	-	-	-	19
23	179.7	180.1	179.0	180.1	178.8	155.2	116.4	-	-	-	-	-	-	-	-	23
26	160.7	161.6	160.3	161.4	160.1	147.9	112.0	99.0	-	-	-	-	-	-	-	26
29	140.4	143.1	142.9	141.8	139.8	140.7	107.6	92.8	82.7	-	-	-	-	-	-	29
33	-	126.1	126.1	124.8	125.2	125.2	103.6	86.4	77.2	67.9	-	-	-	-	-	33
39	-	101.0	101.0	99.9	102.1	100.1	97.0	75.2	67.9	61.1	52.9	-	-	-	-	39
46	-	-	84.7	85.5	84.4	86.2	84.4	67.0	60.2	54.7	48.7	43.2	34.4	-	-	46
52	-	-	70.5	70.1	70.5	70.5	68.3	59.1	54.2	49.2	44.3	40.1	34.4	26.5	-	52
59	-	-	-	59.5	60.2	58.6	56.4	53.1	48.3	44.8	40.6	37.0	32.4	26.5	-	59
65	-	-	-	52.0	51.1	49.6	47.6	47.0	43.4	40.3	37.3	34.4	30.2	26.2	-	65
72	-	-	-	-	44.1	42.5	40.8	42.3	38.4	36.4	34.2	32.0	28.4	25.1	-	72
79	-	-	-	-	38.6	37.0	38.6	36.8	34.4	33.1	30.9	29.5	26.7	23.8	-	79
85	-	-	-	-	-	33.1	34.0	32.0	30.4	29.1	28.7	27.1	25.1	22.5	-	85
92	-	-	-	-	-	31.5	30.0	28.2	28.7	26.2	25.1	25.4	23.4	21.4	-	92
98	-	-	-	-	-	28.2	26.7	25.4	25.6	23.8	23.4	22.3	21.8	20.1	-	98
105	-	-	-	-	-	-	23.8	24.0	22.5	22.7	20.7	20.5	20.7	19.0	-	105
111	-	-	-	-	-	-	21.4	22.0	20.1	20.3	19.4	19.0	18.1	17.9	-	111
118	-	-	-	-	-	-	-	19.6	19.0	17.9	17.6	17.0	15.9	15.7	-	118
124	-	-	-	-	-	-	-	17.6	17.9	16.1	16.1	15.0	13.7	13.7	-	124
131	-	-	-	-	-	-	-	-	15.9	15.2	14.3	13.2	11.9	11.9	-	131
138	-	-	-	-	-	-	-	-	14.3	13.9	12.8	11.5	10.4	10.4	-	138
144	-	-	-	-	-	-	-	-	-	12.3	11.5	10.1	8.8	8.8	-	144
151	-	-	-	-	-	-	-	-	-	11.0	10.1	8.8	7.7	7.5	-	151
157	-	-	-	-	-	-	-	-	-	-	9.0	7.7	6.4	6.4	-	157
164	-	-	-	-	-	-	-	-	-	-	7.9	6.6	5.3	5.3	-	164
177	-	-	-	-	-	-	-	-	-	-	-	4.9	3.5	3.3	-	177



HA LIFTING CAPACITIES

35,900 lb		360°														85 %
Radius	ft	Main boom														Radius
		40.7	54.5	68.6	82.3	96.5	110.2	124.3	138.1	152.2	166.0	180.1	193.9	208.0	222.4	
ft		1,000 lb														ft
10	309.7	309.7	308.6	257.9	-	-	-	-	-	-	-	-	-	-	-	10
11	283.3	283.3	282.2	257.9	-	-	-	-	-	-	-	-	-	-	-	11
13	260.1	260.1	259.0	257.9	198.6	-	-	-	-	-	-	-	-	-	-	13
15	240.3	241.4	240.3	238.1	198.6	-	-	-	-	-	-	-	-	-	-	15
16	223.8	223.8	222.7	221.6	198.6	162.5	-	-	-	-	-	-	-	-	-	16
19	187.6	190.3	187.2	188.7	177.0	162.3	-	-	-	-	-	-	-	-	-	19
23	155.9	158.5	158.3	155.4	148.6	135.6	116.4	-	-	-	-	-	-	-	-	23
26	132.5	134.9	134.9	131.8	122.6	112.9	109.3	99.0	-	-	-	-	-	-	-	26
29	105.8	111.8	113.1	111.8	103.6	101.0	91.9	85.8	79.4	-	-	-	-	-	-	29
33	-	91.7	93.0	92.2	93.5	86.2	78.7	73.9	69.9	65.3	-	-	-	-	-	33
39	-	64.8	69.0	69.2	68.3	65.5	62.6	60.0	55.1	52.9	48.9	34.6	-	-	-	39
46	-	-	52.2	52.5	51.6	52.7	51.8	48.3	45.2	44.1	41.4	38.4	34.4	-	-	46
52	-	-	41.2	41.4	43.4	42.5	41.0	41.2	39.2	36.8	36.6	34.2	31.5	26.5	-	52
59	-	-	-	35.3	35.5	34.6	35.3	33.7	34.0	32.8	30.6	28.2	25.8	24.9	-	59
65	-	-	-	29.8	29.5	30.2	29.3	29.3	28.7	27.6	25.8	23.4	21.2	20.5	-	65
72	-	-	-	-	24.9	25.6	25.4	24.7	24.0	22.9	21.6	19.6	17.4	16.8	-	72
79	-	-	-	-	22.0	21.8	21.6	20.9	20.3	19.2	18.1	16.3	14.3	13.7	-	79
85	-	-	-	-	-	18.7	18.5	17.9	17.2	15.9	14.8	13.7	11.7	11.0	-	85
92	-	-	-	-	-	16.1	15.9	15.2	14.6	13.2	12.1	11.0	9.3	8.6	-	92
98	-	-	-	-	-	13.9	13.7	13.0	12.3	11.0	9.9	8.8	7.3	6.6	-	98
105	-	-	-	-	-	-	11.7	11.0	10.4	9.0	8.2	6.8	5.5	4.9	-	105
111	-	-	-	-	-	-	10.1	9.3	8.6	7.5	6.4	5.1	4.0	3.3	-	111
118	-	-	-	-	-	-	-	7.9	7.3	6.0	5.1	3.7	2.4	-	-	118
124	-	-	-	-	-	-	-	6.6	6.0	4.6	3.7	2.4	-	-	-	124
131	-	-	-	-	-	-	-	-	4.9	3.5	2.6	-	-	-	-	131
138	-	-	-	-	-	-	-	-	3.7	2.6	-	-	-	-	-	138
144	-	-	-	-	-	-	-	-	-	-	-	-	-	-	-	144

19,600 lb		360°														85 %
Radius	ft	Main boom														Radius
		40.7	54.5	68.6	82.3	96.5	110.2	124.3	138.1	152.2	166.0	180.1	193.9	208.0	222.4	
ft		1,000 lb														ft
10	306.4	306.4	306.4	257.9	-	-	-	-	-	-	-	-	-	-	-	10
11	280.0	281.1	280.0	257.9	-	-	-	-	-	-	-	-	-	-	-	11
13	257.9	257.9	256.8	255.7	198.6	-	-	-	-	-	-	-	-	-	-	13
15	238.1	239.2	238.1	235.9	198.6	-	-	-	-	-	-	-	-	-	-	15
16	219.8	220.5	219.4	218.9	196.0	162.5	-	-	-	-	-	-	-	-	-	16
19	176.8	179.2	179.2	165.6	156.5	141.1	-	-	-	-	-	-	-	-	-	19
23	146.6	149.3	142.6	136.5	124.1	119.5	107.6	-	-	-	-	-	-	-	-	23
26	111.6	118.4	119.3	109.8	106.9	97.4	89.5	81.4	-	-	-	-	-	-	-	26
29	86.4	93.0	94.6	95.7	88.8	81.1	76.5	72.5	66.6	-	-	-	-	-	-	29
33	-	74.5	79.1	79.6	75.2	69.2	67.7	62.8	58.4	54.2	-	-	-	-	-	33
39	-	51.6	55.8	56.0	55.1	56.9	52.0	50.5	47.2	45.0	43.9	-	-	-	-	39
46	-	-	41.7	43.2	44.1	43.0	43.0	40.8	39.9	37.5	34.6	31.7	28.9	-	-	46
52	-	-	34.0	34.8	34.6	35.5	34.8	34.6	32.8	30.2	27.8	25.1	22.5	21.4	-	52
59	-	-	-	28.2	28.9	28.7	28.4	27.8	26.9	24.5	22.5	20.1	17.6	16.8	-	59
65	-	-	-	23.1	23.8	23.6	23.4	22.9	22.0	20.1	18.1	15.9	13.7	13.0	-	65
72	-	-	-	-	19.8	19.8	19.4	18.5	17.9	16.5	14.6	12.6	10.4	9.9	-	72
79	-	-	-	-	16.5	16.5	15.9	15.2	14.6	13.2	11.7	9.7	7.7	7.1	-	79
85	-	-	-	-	-	13.7	13.2	12.3	11.7	10.4	9.3	7.5	5.5	4.9	-	85
92	-	-	-	-	-	11.5	10.8	10.1	9.5	8.2	7.1	5.5	3.5	2.9	-	92
98	-	-	-	-	-	9.5	9.0	8.2	7.5	6.2	5.3	3.7	-	-	-	98
105	-	-	-	-	-	-	7.5	6.6	6.0	4.6	3.7	2.2	-	-	-	105
111	-	-	-	-	-	-	6.2	5.3	4.4	3.3	2.2	-	-	-	-	111
118	-	-	-	-	-	-	-	4.0	3.3	-	-	-	-	-	-	118
124	-	-	-	-	-	-	-	3.1	2.2	-	-	-	-	-	-	124
131	-	-	-	-	-	-	-	-	-	-	-	-	-	-	-	131

HA LIFTING CAPACITIES

0 lb		360°													85 %
Radius	ft	Main boom													Radius
		40.7	54.5	68.6	82.3	96.5	110.2	124.3	138.1	152.2	166.0	180.1	193.9	205.7	
ft		1,000 lb													ft
10	303.1	303.1	303.1	257.9	-	-	-	-	-	-	-	-	-	-	10
11	277.8	277.8	276.7	257.9	-	-	-	-	-	-	-	-	-	-	11
13	254.6	255.7	254.6	228.2	187.2	-	-	-	-	-	-	-	-	-	13
15	231.5	231.5	216.5	186.1	160.9	-	-	-	-	-	-	-	-	-	15
16	203.9	206.6	183.0	160.7	142.4	131.2	-	-	-	-	-	-	-	-	16
19	156.3	152.1	139.1	121.7	114.0	99.6	-	-	-	-	-	-	-	-	19
23	104.5	111.6	104.9	100.1	89.5	81.1	76.3	-	-	-	-	-	-	-	23
26	74.1	80.7	86.2	80.7	74.5	70.8	65.0	60.4	-	-	-	-	-	-	26
29	55.8	61.5	66.1	66.4	64.6	59.7	57.1	53.8	49.6	-	-	-	-	-	29
33	-	50.0	52.9	55.3	55.8	51.6	49.8	46.3	42.5	38.1	-	-	-	-	33
39	-	34.4	37.9	39.0	39.9	39.7	37.9	34.8	32.0	28.4	25.6	-	-	-	39
46	-	-	27.6	28.7	29.5	29.3	29.1	26.9	24.7	21.8	19.2	16.3	15.7	-	46
52	-	-	20.7	21.6	22.5	22.3	22.0	21.2	19.2	16.8	14.6	11.9	11.5	-	52
59	-	-	-	16.8	17.4	17.2	17.2	16.5	15.2	12.8	10.8	8.6	8.2	-	59
65	-	-	-	13.2	13.9	13.7	13.4	12.8	11.9	9.7	7.9	5.7	5.5	-	65
72	-	-	-	-	11.0	10.8	10.8	10.1	9.3	7.3	5.5	3.5	3.3	-	72
79	-	-	-	-	8.8	8.6	8.6	7.9	7.1	5.1	3.5	-	-	-	79
85	-	-	-	-	-	6.8	6.8	6.2	5.3	3.3	-	-	-	-	85
92	-	-	-	-	-	5.3	5.1	4.4	3.7	-	-	-	-	-	92
98	-	-	-	-	-	4.0	3.7	2.9	-	-	-	-	-	-	98
105	-	-	-	-	-	-	2.4	-	-	-	-	-	-	-	105



HAV WORKING RANGES

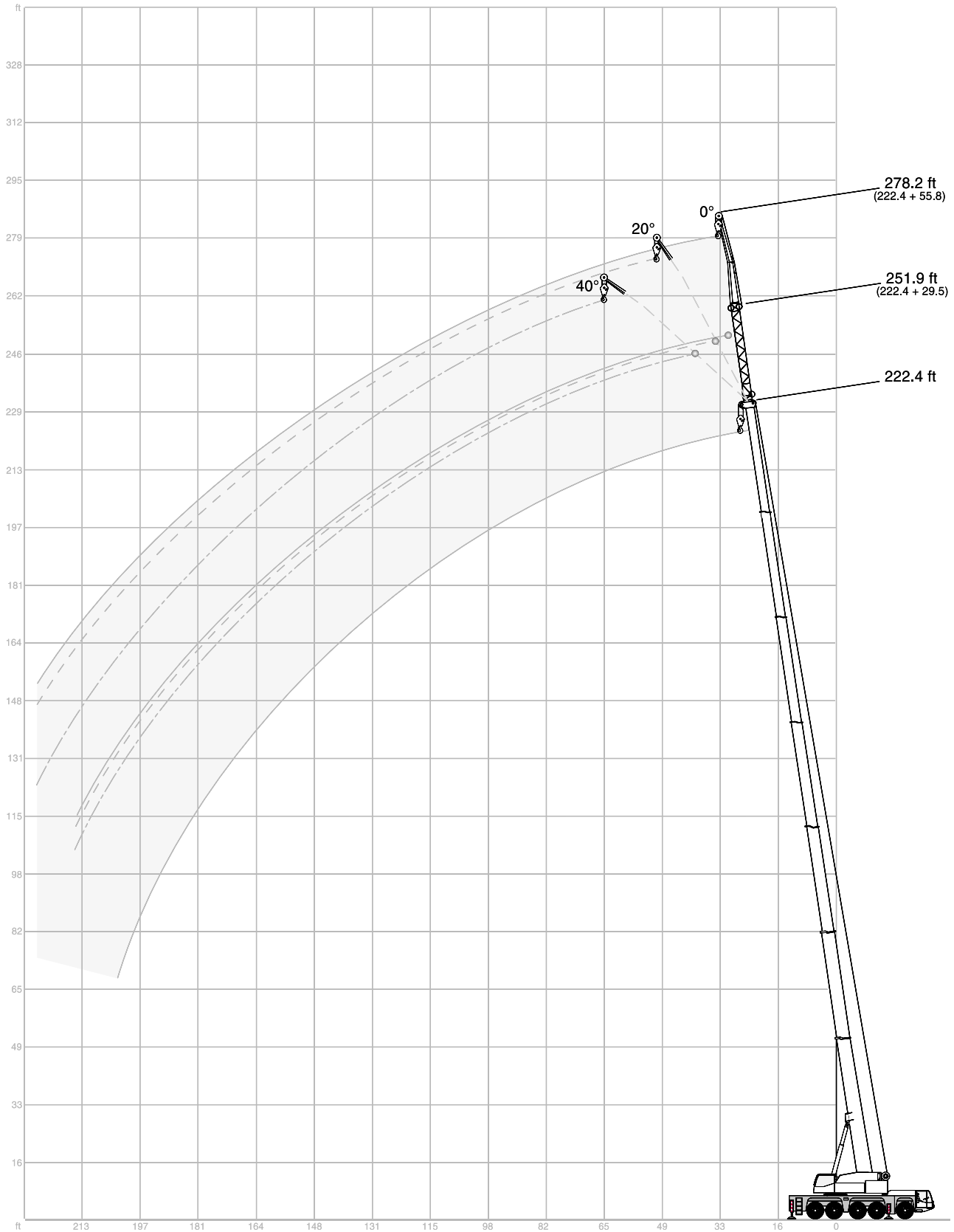

HAV LIFTING CAPACITIES

152,100 lb 360° 85 %

40.7 ft Main boom		Extension					
Radius	29.5 ft			55.8 ft			
	0°	20°	40°	0°	20°	40°	
ft	1,000 lb						
10	39.7	-	-	33.1	-	-	
11	39.7	-	-	32.6	-	-	
13	39.7	-	-	32.2	-	-	
15	39.7	-	-	31.5	-	-	
16	39.7	34.2	-	30.9	-	-	
19	39.7	31.5	-	29.8	-	-	
23	39.7	29.3	22.7	28.2	-	-	
26	38.6	27.6	21.6	26.9	-	-	
29	35.3	25.8	20.7	25.4	21.2	-	
33	31.7	24.3	20.1	24.0	20.3	-	
39	27.1	21.8	18.7	21.8	18.5	-	
46	23.4	19.8	17.6	19.8	17.2	15.2	
52	20.7	18.3	-	18.1	16.1	14.3	
59	18.1	-	-	16.8	15.0	13.7	
65	-	-	-	15.4	14.1	13.2	
72	-	-	-	14.3	13.4	13.0	
79	-	-	-	13.7	13.0	-	
85	-	-	-	-	-	-	
92	-	-	-	-	-	-	
98	-	-	-	-	-	-	
105	-	-	-	-	-	-	
111	-	-	-	-	-	-	
118	-	-	-	-	-	-	

110.2 ft Main boom		Extension					
Radius	29.5 ft			55.8 ft			
	0°	20°	40°	0°	20°	40°	
ft	1,000 lb						
23	39.7	-	-	-	-	-	
26	39.7	-	-	23.1	-	-	
29	39.7	-	-	22.9	-	-	
33	37.9	29.3	-	22.5	-	-	
39	33.7	27.6	20.9	21.6	-	-	
46	30.4	25.8	20.1	20.7	17.4	-	
52	27.1	24.3	19.4	19.6	16.5	-	
59	24.7	22.7	18.7	18.7	15.9	-	
65	22.7	21.2	18.3	17.9	15.2	13.4	
72	20.7	19.8	17.6	16.8	14.6	13.0	
79	19.0	18.3	17.2	15.9	13.7	12.6	
85	17.6	17.0	16.5	14.8	13.0	12.1	
92	16.5	16.1	15.9	13.9	12.3	11.5	
98	15.4	15.0	15.0	12.8	11.9	11.0	
105	14.3	14.1	14.1	12.1	11.2	10.8	
111	13.4	13.2	-	11.5	10.6	10.4	
118	12.8	12.6	-	10.8	10.1	9.9	
124	12.1	11.9	-	9.9	9.7	9.7	
131	-	-	-	9.5	9.3	9.3	
138	-	-	-	9.0	9.0	-	
144	-	-	-	8.6	8.6	-	
151	-	-	-	8.2	8.2	-	
157	-	-	-	-	-	-	

166.0 ft Main boom		Extension					
Radius	29.5 ft			55.8 ft			
	0°	20°	40°	0°	20°	40°	
ft	1,000 lb						
39	33.5	-	-	-	-	-	
46	30.9	-	-	17.9	-	-	
52	28.7	25.1	-	17.4	-	-	
59	26.7	23.8	19.2	17.0	-	-	
65	24.9	22.5	19.0	16.5	14.6	-	
72	23.1	21.4	18.5	15.9	14.1	-	
79	21.4	20.3	18.1	15.4	13.7	12.3	
85	19.6	19.2	17.9	15.0	13.2	12.1	
92	18.3	18.3	17.4	14.6	12.8	11.9	
98	17.2	17.2	17.0	14.1	12.6	11.7	
105	16.1	16.1	16.1	13.4	12.1	11.2	
111	15.0	15.0	15.0	12.8	11.7	11.0	
118	13.9	14.1	14.1	12.1	11.5	10.6	
124	13.0	13.0	13.2	11.5	11.0	10.4	
131	12.3	12.3	12.3	10.8	10.6	10.1	
138	11.5	11.5	11.7	10.1	10.1	9.9	
144	10.8	10.8	11.0	9.7	9.7	9.5	
151	10.1	10.1	10.4	9.3	9.3	9.3	
157	9.5	9.5	-	8.6	8.8	8.8	
164	9.0	9.0	-	8.2	8.4	8.4	
177	8.2	8.2	-	7.3	7.3	7.5	
190	-	-	-	6.4	6.6	-	
203	-	-	-	5.7	5.7	-	

222.4 ft Main boom		Extension					
Radius	29.5 ft			55.8 ft			
	0°	20°	40°	0°	20°	40°	
ft	1,000 lb						
59	17.4	-	-	11.5	-	-	
65	17.4	-	-	11.5	-	-	
72	17.4	17.4	-	11.5	-	-	
79	17.2	17.2	17.2	11.5	-	-	
85	17.2	17.0	17.2	11.5	11.2	-	
92	17.0	16.5	16.8	11.5	11.2	-	
98	16.1	16.1	16.1	11.2	11.0	10.6	
105	15.4	15.4	15.4	11.2	10.8	10.6	
111	14.6	14.6	14.8	11.0	10.8	10.4	
118	13.9	13.9	13.9	10.8	10.6	10.1	
124	13.2	13.2	13.2	10.6	10.4	10.1	
131	12.3	12.3	12.6	10.4	9.9	9.9	
138	11.7	11.7	11.9	10.1	9.7	9.7	
144	11.0	11.0	11.2	9.7	9.5	9.5	
151	10.1	10.4	10.6	9.3	9.3	9.3	
157	9.5	9.7	9.9	8.6	8.8	9.0	
164	8.8	9.0	9.0	8.2	8.4	8.6	
177	7.7	7.7	7.9	7.1	7.5	7.7	
190	6.6	6.6	6.8	6.2	6.4	6.6	
203	5.5	5.5	5.5	5.3	5.5	5.7	
216	4.6	4.6	-	4.4	4.6	4.9	
229	3.3	3.5	-	3.5	3.7	4.0	
243	-	-	-	2.6	3.1	-	

HAV LIFTING CAPACITIES

95,700 lb 360° 85 %

40.7 ft Main boom		Extension					
Radius	29.5 ft			55.8 ft			
	0°	20°	40°	0°	20°	40°	
ft	1,000 lb						
10	39.7	-	-	33.1	-	-	
11	39.7	-	-	32.6	-	-	
13	39.7	-	-	32.2	-	-	
15	39.7	-	-	31.5	-	-	
16	39.7	34.2	-	30.9	-	-	
19	39.7	31.5	-	29.8	-	-	
23	39.7	29.3	22.7	28.2	-	-	
26	38.6	27.6	21.6	26.9	-	-	
29	35.3	25.8	20.7	25.4	21.2	-	
33	31.7	24.3	20.1	24.0	20.3	-	
39	27.1	21.8	18.7	21.8	18.5	-	
46	23.4	19.8	17.6	19.8	17.2	15.2	
52	20.7	18.3	-	18.1	16.1	14.3	
59	18.1	-	-	16.8	15.0	13.7	
65	-	-	-	15.4	14.1	13.2	
72	-	-	-	14.3	13.4	13.0	
79	-	-	-	13.7	13.0	-	
85	-	-	-	-	-	-	
92	-	-	-	-	-	-	
98	-	-	-	-	-	-	
105	-	-	-	-	-	-	
111	-	-	-	-	-	-	
118	-	-	-	-	-	-	

110.2 ft Main boom		Extension					
Radius	29.5 ft			55.8 ft			
	0°	20°	40°	0°	20°	40°	
ft	1,000 lb						
23	39.7	-	-	-	-	-	
26	39.7	-	-	23.1	-	-	
29	39.7	-	-	22.9	-	-	
33	37.9	29.3	-	22.5	-	-	
39	33.7	27.6	20.9	21.6	-	-	
46	30.4	25.8	20.1	20.7	17.4	-	
52	27.1	24.3	19.4	19.6	16.5	-	
59	24.7	22.7	18.7	18.7	15.9	-	
65	22.7	21.2	18.3	17.9	15.2	13.4	
72	20.7	19.8	17.6	16.8	14.6	13.0	
79	19.0	18.3	17.2	15.9	13.7	12.6	
85	17.6	17.0	16.5	14.8	13.0	12.1	
92	16.5	16.1	15.9	13.9	12.3	11.5	
98	15.4	15.0	15.0	12.8	11.9	11.0	
105	14.3	14.1	14.1	12.1	11.2	10.8	
111	13.4	13.2	-	11.5	10.6	10.4	
118	12.8	12.6	-	10.8	10.1	9.9	
124	12.1	11.9	-	9.9	9.7	9.7	
131	-	-	-	9.5	9.3	9.3	
138	-	-	-	9.0	9.0	-	
144	-	-	-	8.6	8.6	-	
151	-	-	-	8.2	8.2	-	
157	-	-	-	-	-	-	

166.0 ft Main boom		Extension					
Radius	29.5 ft			55.8 ft			
	0°	20°	40°	0°	20°	40°	
ft	1,000 lb						
39	33.5	-	-	-	-	-	
46	30.9	-	-	17.9	-	-	
52	28.7	25.1	-	17.4	-	-	
59	26.7	23.8	19.2	17.0	-	-	
65	24.9	22.5	19.0	16.5	14.6	-	
72	23.1	21.4	18.5	15.9	14.1	-	
79	21.4	20.3	18.1	15.4	13.7	12.3	
85	19.6	19.2	17.9	15.0	13.2	12.1	
92	18.3	18.3	17.4	14.6	12.8	11.9	
98	17.2	17.2	17.0	14.1	12.6	11.7	
105	16.1	16.1	16.1	13.4	12.1	11.2	
111	15.0	15.0	15.0	12.8	11.7	11.0	
118	13.9	14.1	14.1	12.1	11.5	10.6	
124	13.0	13.0	13.2	11.5	11.0	10.4	
131	12.3	12.3	12.3	10.8	10.6	10.1	
138	11.5	11.5	11.7	10.1	10.1	9.9	
144	10.8	10.8	11.0	9.7	9.7	9.5	
151	10.1	10.1	10.4	9.3	9.3	9.3	
157	9.5	9.5	-	8.6	8.8	8.8	
164	8.6	9.0	-	8.2	8.4	8.4	
177	6.6	6.8	-	7.3	7.3	7.5	
190	-	-	-	5.7	6.2	-	
203	-	-	-	4.4	4.6	-	

222.4 ft Main boom		Extension					
Radius	29.5 ft			55.8 ft			
	0°	20°	40°	0°	20°	40°	
ft	1,000 lb						
59	17.4	-	-	11.5	-	-	
65	17.4	-	-	11.5	-	-	
72	17.4	17.4	-	11.5	-	-	
79	17.2	17.2	17.2	11.5	-	-	
85	17.2	17.0	17.2	11.5	11.2	-	
92	17.0	16.5	16.8	11.5	11.2	-	
98	16.1	16.1	16.1	11.2	11.0	10.6	
105	15.4	15.4	15.4	11.2	10.8	10.6	
111	14.6	14.6	14.8	11.0	10.8	10.4	
118	13.9	13.9	13.9	10.8	10.6	10.1	
124	13.2	13.2	13.2	10.6	10.4	10.1	
131	11.5	12.3	12.6	10.4	9.9	9.9	
138	9.7	10.8	11.5	10.1	9.7	9.7	
144	8.4	9.3	9.9	8.8	9.5	9.5	
151	7.1	7.9	8.6	7.5	9.3	9.3	
157	5.7	6.6	7.1	6.4	7.9	9.0	
164	4.6	5.5	6.0	5.3	6.8	7.9	
177	2.9	3.5	3.7	3.3	4.6	5.5	
190	-	-	-	-	2.9	3.5	
203	-	-	-	-	-	-	
216	-	-	-	-	-	-	
229	-	-	-	-	-	-	
243	-	-	-	-	-	-	

HAV LIFTING CAPACITIES

152,100 lb 360° 85 %

40.7 ft Main boom						
Radius	Extension					
	82.0 ft			108.3 ft		
	0°	20°	40°	0°	20°	40°
ft	1,000 lb					
16	27.1	-	-	-	-	-
19	26.5	-	-	-	-	-
23	25.1	-	-	20.5	-	-
26	24.0	-	-	19.4	-	-
29	22.7	-	-	18.3	-	-
33	21.6	-	-	17.4	-	-
39	19.4	17.2	-	15.7	-	-
46	17.2	15.4	-	14.1	13.0	-
52	15.9	14.3	13.2	12.6	11.9	-
59	14.3	13.0	12.1	11.2	10.8	10.4
65	12.8	12.1	11.5	10.4	9.9	9.5
72	11.9	11.2	10.8	9.5	9.0	8.8
79	11.0	10.4	10.1	8.6	8.4	8.2
85	10.4	9.9	9.5	7.9	7.7	7.7
92	9.5	9.3	9.3	7.3	7.3	7.1
98	9.0	8.8	8.8	6.8	6.6	6.6
105	8.6	8.4	-	6.2	6.2	6.2
111	-	-	-	5.7	5.7	6.0
118	-	-	-	5.5	5.5	5.5
124	-	-	-	5.3	5.1	-
131	-	-	-	4.9	4.9	-
138	-	-	-	-	-	-
144	-	-	-	-	-	-
151	-	-	-	-	-	-
157	-	-	-	-	-	-
164	-	-	-	-	-	-

110.2 ft Main boom						
Radius	Extension					
	82.0 ft			108.3 ft		
	0°	20°	40°	0°	20°	40°
ft	1,000 lb					
33	18.7	-	-	-	-	-
39	18.1	-	-	13.7	-	-
46	17.2	-	-	12.8	-	-
52	16.3	-	-	12.1	-	-
59	15.4	13.7	-	11.5	-	-
65	14.3	12.8	-	10.8	-	-
72	13.4	12.1	11.2	10.1	-	-
79	12.3	11.5	10.6	9.7	8.4*	-
85	11.7	10.6	10.1	9.0	7.9*	-
92	10.8	9.9	9.5	8.4	7.7*	7.3*
98	10.1	9.3	9.0	7.9	7.3*	7.1*
105	9.5	8.8	8.4	7.5	7.1*	6.8*
111	8.8	8.4	8.2	7.1	6.6*	6.4*
118	8.2	7.9	7.7	6.4	6.4*	6.2*
124	7.9	7.5	7.3	6.0	6.2*	6.0*
131	7.5	7.1	7.1	5.5	6.0*	5.7*
138	7.1	6.8	6.6	5.1	5.5*	5.5*
144	6.6	6.4	6.4	4.9	5.3*	5.3*
151	6.2	6.2	6.2	4.6	5.1*	5.1*
157	6.0	5.7	-	4.4	4.9*	4.9*
164	5.7	5.5	-	4.0	4.6*	4.6*
177	5.3	5.3	-	3.5	4.2*	4.2*
190	-	-	-	3.3	3.7*	3.7*
203	-	-	-	-	3.3*	3.3*
216	-	-	-	-	2.9*	-
229	-	-	-	-	2.4*	-

166.0 ft Main boom						
Radius	Extension					
	82.0 ft			108.3 ft		
	0°	20°	40°	0°	20°	40°
ft	1,000 lb					
52	14.1	-	-	-	-	-
59	13.9	-	-	9.5	-	-
65	13.4	-	-	9.5	-	-
72	12.8	11.7	-	9.3	-	-
79	12.3	11.2	-	8.8	8.2	-
85	11.9	10.8	10.1	8.4	7.9	-
92	11.5	10.4	9.7	8.2	7.5	7.3
98	11.0	9.9	9.5	7.7	7.3	6.8
105	10.4	9.5	9.0	7.5	7.1	6.6
111	9.9	9.3	8.6	7.3	6.6	6.4
118	9.5	8.8	8.4	6.8	6.4	6.2
124	9.3	8.4	7.9	6.6	6.2	6.0
131	8.8	7.9	7.7	6.2	6.0	5.7
138	8.4	7.7	7.3	6.0	5.7	5.5
144	7.9	7.5	7.1	5.7	5.5	5.3
151	7.5	7.1	6.8	5.5	5.3	5.1
157	7.3	6.8	6.6	5.3	5.1	4.9
164	6.8	6.6	6.4	4.9	4.9	4.6
177	6.0	6.0	6.0	4.4	4.4	4.4
190	5.3	5.3	5.3	4.0	4.0	4.0
203	4.6	4.6	4.6	3.5	3.5	3.5
216	4.2	4.2	-	3.1	3.1	3.1
229	3.5	3.5	-	2.6	2.6	-
243	-	-	-	2.2	2.2	-

219.8 ft Main boom						
Radius	Extension					
	82.0 ft			108.3 ft		
	0°	20°	40°	0°	20°	40°
ft	1,000 lb					
65	7.9	-	-	-	-	-
72	7.9	-	-	4.9	-	-
79	7.9	-	-	4.9	-	-
85	7.9	-	-	4.9	-	-
92	7.9	7.7	-	4.9	6.0**	-
98	7.9	7.7	-	4.9	6.0**	-
105	7.9	7.7	7.7	4.9	6.0**	-
111	7.9	7.7	7.7	4.9	6.0**	5.7**
118	7.7	7.7	7.7	4.9	5.7**	5.7**
124	7.7	7.7	7.5	4.9	5.7**	5.7**
131	7.7	7.5	7.3	4.9	5.5**	5.5**
138	7.5	7.3	7.3	4.6	5.5**	5.3**
144	7.5	7.1	7.1	4.6	5.3**	5.1**
151	7.5	7.1	6.8	4.6	5.1**	5.1**
157	7.3	6.8	6.6	4.6	4.9**	4.9**
164	6.8	6.6	6.4	4.6	4.9**	4.9**
177	6.2	6.0	6.2	4.4	4.4**	4.4**
190	5.3	5.5	5.5	4.0	4.2**	4.2**
203	4.6	4.9	4.9	3.5	4.0**	4.0**
216	4.0	4.2	4.4	3.1	3.5**	3.7**
229	3.1	3.5	3.5	2.6	3.1**	3.3**
243	2.4	2.6	2.9	-	2.6**	2.6**
256	-	-	-	-	-	-
269	-	-	-	-	-	-

Remarks: * Main boom 152.2 ft ** Main boom 208.0 ft

HAV LIFTING CAPACITIES

95,700 lb 360° 85 %

40.7 ft Main boom						
Radius	Extension					
	82.0 ft			108.3 ft		
	0°	20°	40°	0°	20°	40°
ft	1,000 lb					
16	27.1	-	-	-	-	-
19	26.5	-	-	-	-	-
23	25.1	-	-	20.5	-	-
26	24.0	-	-	19.4	-	-
29	22.7	-	-	18.3	-	-
33	21.6	-	-	17.4	-	-
39	19.4	17.2	-	15.7	-	-
46	17.2	15.4	-	14.1	13.0	-
52	15.9	14.3	13.2	12.6	11.9	-
59	14.3	13.0	12.1	11.2	10.8	10.4
65	12.8	12.1	11.5	10.4	9.9	9.5
72	11.9	11.2	10.8	9.5	9.0	8.8
79	11.0	10.4	10.1	8.6	8.4	8.2
85	10.4	9.9	9.5	7.9	7.7	7.7
92	9.5	9.3	9.3	7.3	7.3	7.1
98	9.0	8.8	8.8	6.8	6.6	6.6
105	8.6	8.4	-	6.2	6.2	6.2
111	-	-	-	5.7	5.7	6.0
118	-	-	-	5.5	5.5	5.5
124	-	-	-	5.3	5.1	-
131	-	-	-	4.9	4.9	-
138	-	-	-	-	-	-
144	-	-	-	-	-	-

110.2 ft Main boom						
Radius	Extension					
	82.0 ft			108.3 ft		
	0°	20°	40°	0°	20°	40°
ft	1,000 lb					
33	18.7	-	-	-	-	-
39	18.1	-	-	13.7	-	-
46	17.2	-	-	12.8	-	-
52	16.3	-	-	12.1	-	-
59	15.4	13.7	-	11.5	-	-
65	14.3	12.8	-	10.8	9.9	-
72	13.4	12.1	11.2	10.1	9.5	-
79	12.3	11.5	10.6	9.7	8.8	8.4
85	11.7	10.6	10.1	9.0	8.4	7.9
92	10.8	9.9	9.5	8.4	7.9	7.5
98	10.1	9.3	9.0	7.9	7.5	7.3
105	9.5	8.8	8.4	7.5	7.1	6.8
111	8.8	8.4	8.2	7.1	6.6	6.4
118	8.2	7.9	7.7	6.4	6.2	6.0
124	7.9	7.5	7.3	6.0	6.0	5.7
131	7.5	7.1	7.1	5.5	5.5	5.5
138	7.1	6.8	6.6	5.1	5.1	5.1
144	6.6	6.4	6.4	4.9	4.9	4.9
151	6.2	6.2	6.2	4.6	4.4	4.4
157	6.0	5.7	-	4.4	4.2	4.2
164	5.7	5.5	-	4.0	4.0	4.0
177	5.3	5.3	-	3.5	3.5	3.5
190	-	-	-	3.3	3.3	-

166.0 ft Main boom						
Radius	Extension					
	82.0 ft			108.3 ft		
	0°	20°	40°	0°	20°	40°
ft	1,000 lb					
52	14.1	-	-	-	-	-
59	13.9	-	-	9.5	-	-
65	13.4	-	-	9.5	-	-
72	12.8	11.7	-	9.3	-	-
79	12.3	11.2	-	8.8	8.2	-
85	11.9	10.8	10.1	8.4	7.9	-
92	11.5	10.4	9.7	8.2	7.5	7.3
98	11.0	9.9	9.5	7.7	7.3	6.8
105	10.4	9.5	9.0	7.5	7.1	6.6
111	9.9	9.3	8.6	7.3	6.6	6.4
118	9.5	8.8	8.4	6.8	6.4	6.2
124	9.3	8.4	7.9	6.6	6.2	6.0
131	8.8	7.9	7.7	6.2	6.0	5.7
138	8.4	7.7	7.3	6.0	5.7	5.5
144	7.9	7.5	7.1	5.7	5.5	5.3
151	7.5	7.1	6.8	5.5	5.3	5.1
157	7.3	6.8	6.6	5.3	5.1	4.9
164	6.8	6.6	6.4	4.9	4.9	4.6
177	6.0	6.0	6.0	4.4	4.4	4.4
190	5.3	5.3	5.3	4.0	4.0	4.0
203	4.2	4.6	4.6	3.5	3.5	3.5
216	2.9	3.3	-	2.9	3.1	3.1
229	-	-	-	-	2.2	-

219.8 ft Main boom						
Radius	Extension					
	82.0 ft			108.3 ft		
	0°	20°	40°	0°	20°	40°
ft	1,000 lb					
65	7.9	-	-	-	-	-
72	7.9	-	-	4.9	-	-
79	7.9	-	-	4.9	-	-
85	7.9	-	-	4.9	-	-
92	7.9	7.7	-	4.9	6.0**	-
98	7.9	7.7	-	4.9	6.0**	-
105	7.9	7.7	7.7	4.9	6.0**	-
111	7.9	7.7	7.7	4.9	6.0**	5.7**
118	7.7	7.7	7.7	4.9	5.7**	5.7**
124	7.7	7.7	7.5	4.9	5.7**	5.7**
131	7.7	7.5	7.3	4.9	5.5**	5.5**
138	7.5	7.3	7.3	4.6	5.5**	5.3**
144	7.5	7.1	7.1	4.6	5.3**	5.1**
151	7.3	7.1	6.8	4.6	5.1**	5.1**
157	6.2	6.8	6.6	4.6	4.9**	4.9**
164	5.3	6.6	6.4	4.6	4.9**	4.9**
177	3.3	4.9	6.0	2.9	4.4**	4.4**
190	-	3.1	4.0	-	3.3**	4.2**
203	-	-	-	-	-	2.6**
216	-	-	-	-	-	-
229	-	-	-	-	-	-
243	-	-	-	-	-	-
256	-	-	-	-	-	-

Remarks

** Main boom 208.0 ft

HAV WORKING RANGES

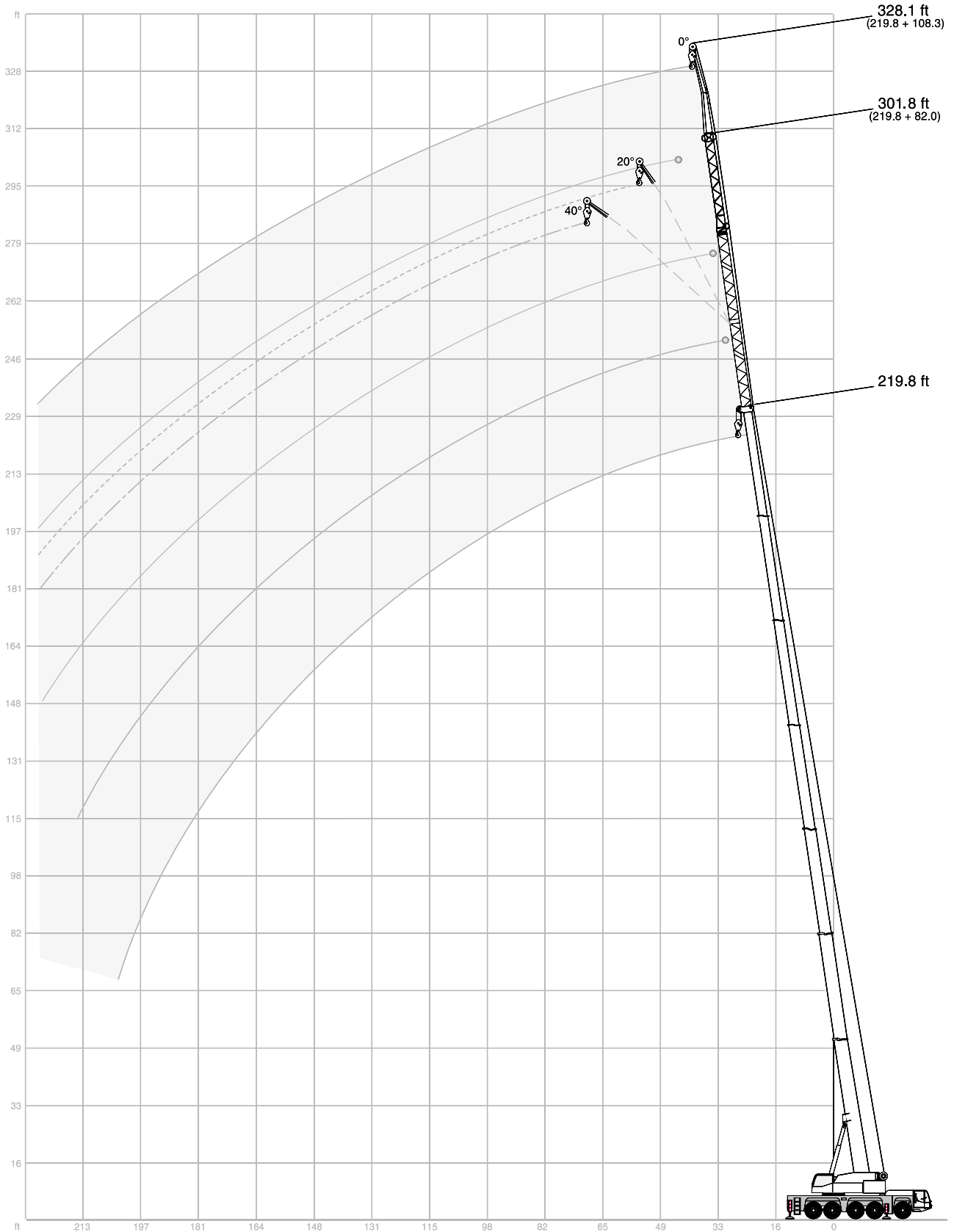

TECHNICAL DESCRIPTION

CARRIER

Drive / Steering	10 x 8 x 8.
Frame	Torsion-resistant box girder frame fabricated from high-strength fine grain structural steel.
Outriggers	4 telescopic outriggers, fabricated from fine grain structural steel, fully hydraulic horizontal and vertical extension.
Engine	Water-cooled 8 cylinder DaimlerChrysler diesel engine OM 502 LA, rating 390 kW (530 HP) at 1800 ¹ /min, torque 2400 Nm at 1300 ¹ /min, EUROMOT 3a. Fuel tank capacity: 132 gallons.
Transmission	ZF AS-Tronic, electronically automated transmission with automatic clutch, 16 forward and 2 reverse speeds with integrated retarder, 2-range transfer case, cruise control.
Axles	Axles 2, 3, 4, and 5: driven, 1, 2, 4, and 5: steering. Transverse differential lockout control on axles 2, 3, 4, and 5. Longitudinal lockout control on axles 3 and 4.
Suspension	Hydro-pneumatic suspension on all axles, hydraulically lockable for on-site travel.
Wheels and tires	10 wheels fitted with 14.00 R 25 tires (Michelin or Bridgestone).
Steering	10 x 8, axle 1+2: ZF dual-circuit semiblock mechanical steering with hydraulic booster and mechanical steering limiter. Axle 4+5: speed-depending steering for on-road drive, special steering programs to be selected off-road.
Brakes	To EC directives, sustained action brake: hydraulic retarder integrated into gearbox. Exhaust brake and constant choke valve.
Electrical equipment	24 V system.
Driver's cab	Highly comfortable ergonomic cab with clearly arranged dashboard, rubber mounted steel cab, corrosion-resistant powder coating with 2-pack top coat. 9.8 ft wide, 2 comfortable seats, with pneumatically sprung and heated driver's seat incl. head and arm rests, and three-point seat belts, vertically adjustable steering wheel, safety glass used throughout, electric windows, heated and electrically adjustable mirrors, windscreen defroster fans, engine-dependent hot water heater, electric windscreen washer and wiper, roller blinds, radio with CD player, stowage compartment, air-conditioning.

SUPERSTRUCTURE

Engine	Water-cooled 6 cylinder DaimlerChrysler diesel engine OM 906 LA, rating 170 kW (231 HP) at 2200 ¹ /min, torque 810 Nm at 1200-1600 ¹ /min. Fuel tank capacity: 132 gallons (on carrier).
Hydraulic system	Two variable displacement axial piston pumps with automatic power control enabling the operator to engage four independent working movements simultaneously, separate pump for slewing. Hydraulic oil cooler included as standard.
Hoist	Fixed displacement axial piston hydraulic motor, hoist drum with integrated planetary gear reducer, and spring-applied multi-disk brake. Hydraulic brake, drum rotation indicator.
Slew unit	Hydraulic motor with planetary gear reducer, pedal-operated brake, joystick-actuated free swing, spring-applied holding brake.
Boom elevation	1 differential cylinder with automatic lowering brake valve.
Crane cab	Highly comfortable cab with sliding door, roof window and large hinged windscreen, safety glass used throughout, sprung and hydraulically damped operator's seat with head and arm rests, wiper for windscreen and roof window, self-contained hot water heater with timer and 'Heizmatic' for sensitive heat flow control, dashboard with instrumentation and crane controls, e.g. drum rotation indicator for hoists I and II, load moment limiter, outrigger loading indicator, two working lights, air-conditioning. The crane cab can be tilted back hydraulically 18°.
Main boom	Boom base and 6 telescopic sections fabricated from fine grain structural steel, anti-deflection Demag Ovaloid profile.
Counterweight	152,100 lb hydraulically stowed on carrier.
Operator aids	Electronic load moment indicator with graphic display and touchscreen, digital readout for hook load, rated load, boom length and angle, radius, monitoring code to assist in trouble shooting, and analog display to indicate capacity utilization in %, integrated control system for boom telescoping, display for duty charts and theoretical and actual outrigger loading. Working range limitation to certain pre-defined slew angles, heights and radii („virtual walls“) included as standard.

OPTIONAL EQUIPMENT

Runner	5.4 ft, 2-sheaves.
Twist arrestor	To prevent the hoist ropes from twisting.
Heavy-lift attachment	2 additional sheaves on boom head, max. lifting capacity 324,500 lb, 16 parts of line. The max. lifting capacity of the standard crane without heavy-lift attachment is 249,100 lb (6 sheaves on boom head).
Emergency control	Interface for emergency control to recover small loads, incl. transformer. With hydraulic motor and hydraulic pump available on request.
Warning light	For boom and attachments.
Rooster sheave	Sheave on boom head folding to the side of the boom, for single-line operation.
Wheels and tires	10 wheels fitted with 16.00 R 25 tires.
Main boom extension	Boom extension hydraulically offsetable under partial load up to 40°.

NOTES TO LIFTING CAPACITY

Lifting capacities do not exceed 85% of tipping load.
Weight of hook blocks and slings is part of the load, and is to be deducted from the capacity ratings.
Consult operation manual for further details.

Note: Data published herein is intended as a guide only and shall not be construed to warrant applicability for lifting purposes.
Crane operation is subject to the computer charts and operation manual both supplied with the crane.

KEY

 Counterweight

 Lifting capacities on outriggers 360°

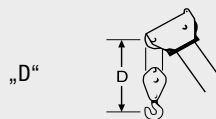

HA: Main boom

HAV: Main boom extension

The information contained in this brochure merely consists of general descriptions and a broad compilation of performance features which might not apply precisely as described under specific application conditions or which may change as a result of further product development. The desired performance features only become binding once expressly agreed in the final contract.

Note: Data published herein is intended as a guide only and shall not be construed to warrant applicability for lifting purposes. Crane operation is subject to the computer charts and operation manual both supplied with the crane.

Subject to change without notice.

11 / 06

Terex Cranes Wilmington Operations

Mobile hydraulic and lattice-boom cranes
202 Raleigh St. · Wilmington, NC 28412 USA
Phone +1 910 395 8500 · Fax +1 910 395 8538
Email: american@american-crane.com