

# Technical Data

## Specifications & Capacities



# ATC 3200

Telescopic Boom All Terrain Crane  
200 ton (181.44 metric ton)

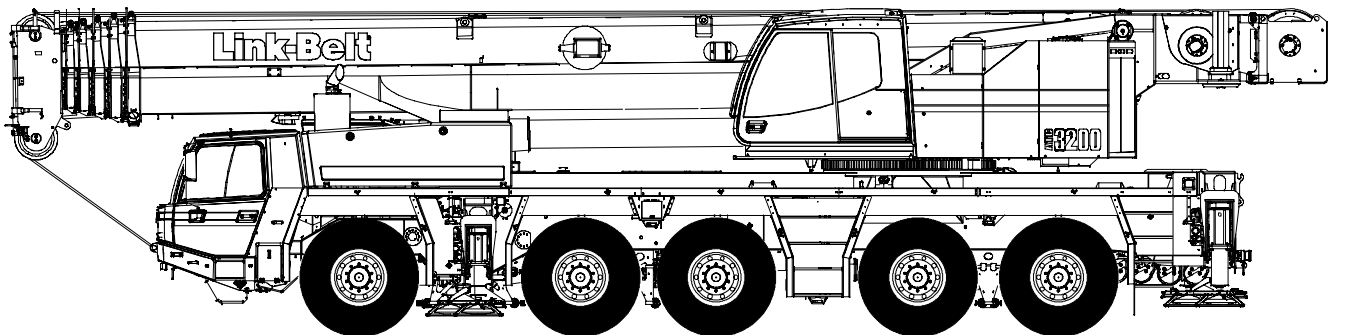

**CAUTION:** This material is supplied for reference use only. Operator must refer to in-cab Crane Rating Manual and Operator's Manual to determine allowable crane lifting capacities and assembly and operating procedures.

## MUNNA CONSTRUCTION COMPANY PVT. LTD.

Office Address: Munna Construction Co. Pvt. Ltd. , 277 Shree Balajee Bhawan, Road no 1, Hill View Colony, Dimna, Mango, Jamshedpur, Jharkhand 831018.

Email: [info@munnaconstruction.com](mailto:info@munnaconstruction.com); [mccpl.bsl@gmail.com](mailto:mccpl.bsl@gmail.com)

Phone: +91 9431735332;

Website: [www.munnaconstruction.com](http://www.munnaconstruction.com)



# Table Of Contents

<b>Boom, Attachments, and Upper Structure</b> .....	<b>1</b>
Boom .....	1
Boom Head .....	1
Boom Elevation .....	1
Auxiliary Lifting Sheave – Optional .....	1
Heavy Lifting Sheave Package – Optional .....	1
Hook Blocks and Balls – Optional .....	1
Fly – Optional .....	1
Fly Inserts – Optional .....	1
Upper Operator’s Cab and Controls .....	2
Swing .....	3
Central Lubrication System .....	3
Electrical .....	3
Hydraulic System .....	3
Pump Drive .....	3
Fuel Tank .....	3
Engine .....	3
Load Hoist System .....	4
Main and Auxiliary (Optional) Winches .....	4
Counterweight .....	4
<b>Carrier</b> .....	<b>6</b>
General .....	6
Outriggers .....	6
Steering and Axles .....	6
Suspension .....	6
Ground Control Outrigger/Suspension Controls .....	7
Tires and Wheels .....	7
Brakes .....	7
Central Lubrication System .....	7
Electrical .....	7
Engine .....	7
Transmission .....	7
Fuel Tank .....	7
Hydraulic System .....	7
Cab and Controls .....	8
Additional Equipment .....	8
Carrier Speeds and Gradeability .....	9
<b>Axle Loads – English</b> .....	<b>10</b>
<b>Axle Loads – Metric</b> .....	<b>11</b>
<b>Axle Loads with 2–Axle or 3–Axle Boom Dolly (3rd Axle Down) – English</b> .....	<b>12</b>
<b>Axle Loads with 2–Axle or 3–Axle Boom Dolly (3rd Axle Down) – Metric</b> .....	<b>13</b>
<b>Axle Loads with 2–Axle or 3–Axle Boom Dolly (3rd Axle Lifted) – English</b> .....	<b>14</b>
<b>Axle Loads with 2–Axle or 3–Axle Boom Dolly (3rd Axle Lifted) – Metric</b> .....	<b>15</b>
<b>General Dimensions</b> .....	<b>16</b>

<b>Working Range Diagram</b> .....	<b>17</b>
<b>Boom Extend Modes</b> .....	<b>18</b>
<b>Main Boom Lift Capacity Charts</b> .....	<b>19</b>
112,435 lb Counterweight – Fully Extended Outriggers – 360° Rotation .....	19
81,570 lb Counterweight – Fully Extended Outriggers – 360° Rotation .....	20
55,115 lb Counterweight – Fully Extended Outriggers – 360° Rotation .....	21
28,660 lb Counterweight – Fully Extended Outriggers – 360° Rotation .....	22
0 lb Counterweight – Fully Extended Outriggers – 360° Rotation .....	23
<b>Fly Attachment Lift Capacity Charts – Optional</b> .....	<b>24</b>
112,435 lb Counterweight – Fully Extended Outriggers – 360° Rotation .....	24
43.3 ft Main Boom Length .....	24
17.7 ft Offset Fly .....	24
186.0 ft Main Boom Length .....	24
17.7 ft Offset Fly .....	24
196.9 ft Main Boom Length .....	24
17.7 ft Offset Fly .....	24
112,435 lb Counterweight – Fully Extended Outriggers – 360° Rotation .....	25
196.9 ft Main Boom Length .....	25
43.3 ft Offset Fly .....	25
63.0 ft Offset Fly .....	25
82.7 ft Offset Fly .....	25
102.4 ft Offset Fly .....	25
122.0 ft Offset Fly .....	25
112,435 lb Counterweight – Fully Extended Outriggers – 360° Rotation .....	26
186.0 ft Main Boom Length .....	26
43.3 ft Offset Fly .....	26
63.0 ft Offset Fly .....	26
82.7 ft Offset Fly .....	26
102.4 ft Offset Fly .....	26
122.0 ft Offset Fly .....	26
81,570 lb Counterweight – Fully Extended Outriggers – 360° Rotation .....	27
43.3 ft Main Boom Length .....	27
17.7 ft Offset Fly .....	27
186.0 ft Main Boom Length .....	27
17.7 ft Offset Fly .....	27
196.9 ft Main Boom Length .....	27
17.7 ft Offset Fly .....	27
81,570 lb Counterweight – Fully Extended Outriggers – 360° Rotation .....	28
196.9 ft Main Boom Length .....	28
43.3 ft Offset Fly .....	28
63.0 ft Offset Fly .....	28
82.7 ft Offset Fly .....	28
102.4 ft Offset Fly .....	28
122.0 ft Offset Fly .....	28

81,570 lb Counterweight – Fully Extended Outriggers – 360° Rotation .....	29
186.0 ft Main Boom Length .....	29
43.3 ft Offset Fly .....	29
63.0 ft Offset Fly .....	29
82.7 ft Offset Fly .....	29
102.4 ft Offset Fly .....	29
122.0 ft Offset Fly .....	29
55,115 lb Counterweight – Fully Extended Outriggers – 360° Rotation .....	30
43.3 ft Main Boom Length .....	30
17.7 ft Offset Fly .....	30
186.0 ft Main Boom Length .....	30
17.7 ft Offset Fly .....	30
196.9 ft Main Boom Length .....	30
17.7 ft Offset Fly .....	30
55,115 lb Counterweight – Fully Extended Outriggers – 360° Rotation .....	31
196.9 ft Main Boom Length .....	31
43.3 ft Offset Fly .....	31
63.0 ft Offset Fly .....	31
82.7 ft Offset Fly .....	31
102.4 ft Offset Fly .....	31
122.0 ft Offset Fly .....	31
55,115 lb Counterweight – Fully Extended Outriggers – 360° Rotation .....	32
186.0 ft Main Boom Length .....	32
43.3 ft Offset Fly .....	32
63.0 ft Offset Fly .....	32
82.7 ft Offset Fly .....	32
102.4 ft Offset Fly .....	32
122.0 ft Offset Fly .....	32
28,660 lb Counterweight – Fully Extended Outriggers – 360° Rotation .....	33
43.3 ft Main Boom .....	33
17.7 ft Offset Fly .....	33
186.0 ft Main Boom .....	33
17.7 ft Offset Fly .....	33
43.3 ft Offset Fly .....	33
196.9 ft Main Boom .....	33
17.7 ft Offset Fly .....	33
43.3 ft Offset Fly .....	33

**This Page Intentionally Blank**

# Boom, Attachments, and Upper Structure

## ■ Boom

**Design** – Six section, formed construction of extra high tensile steel consisting of one base section and five telescoping sections. The two plate design of each section has multiple longitudinal bends for superior strength. Each telescoping section extends independently by means of one double-acting, single stage hydraulic cylinder with an integrated holding valve.

### Boom

- 43.3–196.9 ft (13.2–60.0m) six section boom
- Four pinned positions of 0%, 46%, 93%, and 100% on each boom section provide twenty-nine extend combinations for superior capacities when varying the extension of the telescoping sections, controlled from the operator's cab.
- Integral boom dolly connection
- Mechanical boom angle indicator
- Wind speed indicator
- Maximum tip height for the following boom lengths are:

Boom Length (Pinned Positions)		Tip Height	
ft	m	ft	m
196.9	60.0	208.3	63.5
186.0	56.7	197.5	60.2
171.9	52.4	183.5	55.9
157.5	48.0	169.2	51.6
143.3	43.7	155.0	47.3
128.9	39.3	140.8	42.9
114.8	35.0	126.7	38.6
100.4	30.6	112.4	34.2
86.3	26.3	98.3	30.0
71.9	21.9	84.0	25.6
57.7	17.6	69.9	21.3
43.3	13.2	55.6	16.9

### Boom Head

- Seven 18.2 in (46.2cm) root diameter nylon sheaves to handle up to fourteen parts of line
- Easily removable wire rope guards
- Rope dead end lugs on one side of the boom head
- Boom head is designed for quick-reeve of the hook block

### Boom Elevation

- One double acting hydraulic cylinder with integral holding valve
- Boom elevation:  $-1.5^{\circ}$  to  $84^{\circ}$
- **Load Comp** – Load compensator maintains a consistent radius during load lift-off by automatically elevating boom hoist cylinder. Operated by a switch from the operator's cab.

### Auxiliary Lifting Sheave – Optional

- Single 18.2 in (46.2cm) root diameter nylon sheave
- Easily removable wire rope guards
- Does not affect erection of the fly or use of the main head sheaves

### Heavy Lifting Sheave Package – Optional

- Two 18.2 in (46.2cm) root diameter nylon sheaves
- Easily removable wire rope guards
- Does not affect erection of the fly or use of the main head sheaves
- Necessary to achieve greater than 15 parts of line lifts

### Hook Blocks and Balls – Optional

- 27.6 ton (25.0mt) 1 sheave quick-reeve hook block with safety latch
- 88.2 ton (80.0mt) 5 sheave quick-reeve hook block with safety latch
- 200 ton (181.4mt) 11 sheave quick-reeve hook block with safety latch
- 11 ton (10.0mt) swivel hook ball with safety latch

### Fly – Optional

- 17.7 ft–43.3 ft (5.4–13.2m) two piece lattice fly, stowable, offsettable to  $0^{\circ}$ ,  $20^{\circ}$ , and  $40^{\circ}$ . Maximum tip height is 251.4 ft (76.6m).

### Fly Inserts – Optional

- Four 19.7 ft (6.0m) lattice inserts to be mounted between the 17.7 ft (5.4m) lattice fly base and the 25.6 ft (7.8m) lattice fly tip option. Maximum tip heights for the following fly lengths are:

Fly Length		Tip Height	
ft	m	ft	m
63.0	19.2	271.0	82.6
82.7	25.2	290.5	88.5
102.4	31.2	310.1	94.5
122.1	37.2	329.7	100.5

## ■ Upper Operator's Cab and Controls

**Environmental Cab** – Fully enclosed, one person cab of galvanneal steel structure with acoustical insulation.

Equipped with:

- Tilting interior where the operator's seat, joystick controllers, floor controls and pedals, and main console tilt within the cab
- Tinted and tempered glass windows
- Extra–large power up/power down front window with windshield wiper and washer
- Fixed roof window with windshield wiper
- Sliding left side door with large fixed window
- Fold out rear window for ventilation
- Fixed right side window
- Six way adjustable, cushioned seat with headrests, adjustable lumbar support, and seat belt
- Engine dependent warm–water heater with air ducts for front windshield defroster and cab floor
- AM/FM stereo with single disc CD player
- 12 volt and 24 volt power connections
- Engine hourmeter
- Rated capacity limiter override
- Adjustable sun visor
- Dome light
- Cup holder
- Fire extinguisher
- Left side viewing mirror
- Integral recessed cabwalks
- One position travel swing lock

**Air Conditioning** – Integral with cab heating system utilizing the same ventilation outlets

**Armrest Controls** – Two dual axis electronic joystick controllers for:

- Swing
- Boom hoist
- Boom telescope
- Main front winch
- Auxiliary rear winch – optional
- Drum rotation indicator(s)
- Winch high/low speed and disable switch(es)
- Free swing/automatic swing brake switch
- Auxiliary winch/telescope switch
- High speed function button
- Warning horn

**Foot Controls**

- Swing brake
- Engine throttle

**Front Main Console** – Controls and indicators for:

- Emergency shut down switch
- Central warning indication
- Outrigger controls

**Right Side Console** – Controls and indicators for:

- Auxiliary winch disable switch
- Swing override switch
- Drum rotation indicator activation switch
- Telescopic override switches
- Engine shutdown switch
- Anti–two block override switch

**Right Side Overhead Console** – Controls and indicators for:

- Central lubrication system switch
- Boom and cab floodlight switches
- Top windshield wiper switch
- Front windshield wiper and washer switch
- Power up/power down front windshield switch
- Tilting interior switch
- Battery main shutoff switch
- Supplementary heater controls

**Cockpit Graphic Control (CGC)** – Ergonomically positioned on the front main console, digital instrumentation, and control for crane operations including:

- Engine coolant temperature
- Electronic bubble level and levelness readout
- CAN–BUS diagnostic and engine electronic fault indicator
- Swing lock indicator
- Hydraulic oil and air cleaner filter indicator
- Hydraulic oil temperature
- Low engine oil pressure indicator
- Low voltage indicator
- Fuel level
- Carrier engine start and stop
- Carrier park brake indicator
- Suspension lock indicator
- Axle lift indicator
- Outrigger operation
- Outrigger force readout – optional

**Rated Capacity Limiter** – Graphic audio–visual warning system integrated into the front main console with anti–two block and function limiter. Operating data available includes:

- Crane configuration
- Boom length and angle
- Boom head height
- Allowed load and % of allowed load
- Boom angle
- Radius of load
- Actual load
- Wind speed
- Operator settable alarms (include):
  - Maximum and minimum boom angles
  - Maximum and minimum tip height
  - Maximum boom length
  - Left/right swing positions
  - Work radius



## ■ Swing

**Motor/Planetary** – Bi-directional hydraulic swing motor mounted to a planetary reduction unit for 360° continuous smooth swing at 1.8 rpm. Free swing capable when controller within the operator's cab is in the neutral position.

**Swing Park Brake** – 360°, electric over hydraulic, (spring applied/hydraulic released) multi-disc brake mounted on the reduction unit. Operated by a switch from the operator's cab.

**Swing Brake** – 360°, foot operated, hydraulic applied disc brake mounted to the reduction unit.

**Swing Lock** – One-position swing lock (boom over rear) operated from the operator's cab.

**Automatic Swing Brake Mode** – Swing brake applies when controller within the operator's cab is in the neutral position. Operated by a switch from the operator's cab.

**360° Positive Swing Lock – Optional** – Meets New York City requirement.

## ■ Central Lubrication System

Automated lubrication unit that injects grease into the turntable bearing, boom hoist cylinder pins, boom foot pin, and the main (front) and auxiliary (rear) winch. Operated by a switch from the operator's cab.

## ■ Electrical

Two batteries provide 24-volt operation and starting. CAN bus wiring and components, and integral self-test CSS (Control & Service System).

**Swing Alarm** – Audio warning device signals when the upper is swinging.

### Lights

- Two working lights on front of the cab
- One rotating amber beacon on the right side of the main winch
- One boom floodlight on the boom base section
- Two side marker lights on the boom head

## ■ Hydraulic System

### Main Pumps

- Two variable displacement piston pumps for the main and auxiliary winches, boom hoist and telescope
- One fixed displacement piston pump for the counterweight removal, and swing
- One fixed displacement gear pump for pilot pressure
- One fixed displacement gear pump for telescope pinning
- The upper engine powers the pumps. Combined pump capacity of 170.7 gpm (645Lpm).
- Remote mounted, auxiliary hydraulic oil cooler

**Pump Control “fine inching” Mode** – Special fine metering pump settings, selectable from the operator's cab, allows very slow movements to the main and auxiliary winches, boom hoist, and swing for precision work.

**Pump Control “high speed” Mode** – Boosts hydraulic oil flow by combining the two variable displacement piston pumps for the main and auxiliary winches, boom hoist up, and telescope extend. Operated by a button on the right joystick controller from the operator's cab.

**Hydraulic Reservoir** – 268 gal (1 014L) capacity equipped with sight level gauge. Diffusers built in for deaeration.

**Filtration** – One 12 micron, full flow, line filter in the control circuit. All oil is filtered prior to return to sump tank. Accessible for easy filter replacement.

**Counterbalance Valves** – All hoist motors, boom extend cylinders, and boom hoist cylinders are equipped with counterbalance valves to provide load lowering and prevents accidental load drop when hydraulic power is suddenly reduced.

**Boom Hoist Float Valves** – For transporting the boom over the rear of the crane with a boom dolly. Allows hydraulic oil within the boom hoist cylinder to flow between piston side and case side.

**Swing Brake Release Valve** – For transporting the boom over the rear of the crane with a boom dolly. Holds the 360° swing park brake in the release position allowing free rotation of the upperstructure.

## ■ Pump Drive

All functions are hydraulically powered allowing positive, precise control with independent or simultaneous operation of all functions.

## ■ Fuel Tank

One 66.0 gal (250L) capacity tank.

## ■ Engine

Specification	Mercedes Benz OM 906 LA
Numbers of cylinders	6
Cycle	4
Bore and Stroke: inch (mm)	4.02 x 5.12 (102x130)
Piston Displacement: in <sup>3</sup> (cm <sup>3</sup> )	388.72 (6 374)
Max. Brake Horsepower: hp (kW)	185 (138) @ 1,800 rpm
Peak Torque: ft lb (Nm)	553 (750) @ 1,200 rpm
Alternator: volts – amps	24 – 30
Crankcase Capacity: qt (L)	30.64 (29)
<ul style="list-style-type: none"> <li>• Webasto Engine/Cab Heater – Diesel fired heating unit that can be used for preheating of the engine, or for engine preheating combined with heating of the operator's cab.</li> </ul>	

Main (Front) and Auxiliary (Rear) Winches – 0.83 in (21mm) Rope										
Layer	Maximum Line Pull		Normal Line Speed		High Line Speed		Layer		Total	
	lb	kg	ft/min	m/min	ft/min	m/min	ft	m	ft	m
1	21,010	9 530	237	72.3	360	109.6	169	51.5	169	51.5
2	19,517	8 853	256	77.9	388	118.3	182	55.4	351	106.9
3	18,203	8 257	274	83.4	416	126.8	195	59.4	546	166.3
4	17,066	7 741	292	89.0	444	135.2	208	63.3	753	229.6
5	16,078	7 293	310	94.5	471	143.7	221	67.3	974	296.9
6	15,168	6 880	328	100.1	499	152.2	234	71.3	1,208	368.2
7	14,385	6 525	347	105.7	527	160.6	247	75.2	1,455	443.4

Wire Rope Application	Diameter		Type	Maximum Permissible Load	
	in	mm		lb	kg
Main (Front) Winch	0.83	21	15x7 (35x7 class) rotation resistant –right lang lay	16,673	7 563
Auxiliary (Rear) Winch	0.83	21	15x7 (35x7 class) rotation resistant –right lang lay	16,673	7 563

## ■ Load Hoist System

### Main and Auxiliary (Optional) Winches

- Axial piston, constant displacement motors driven through planetary reduction unit for positive control under all load conditions
- Grooved lagging
- Power up/down mode of operation
- Third wrap indicator with function lockout
- Drum rotation indicator
- Wire rope with “Superstop” easy reeving system
- Drum diameter: 20.67 in (525mm)
- Rope diameter: 0.83 in (21mm)
- Rope length:
  - Main: 1,017 ft (310m)
  - Auxiliary: 820 ft (250m)

**Integrated Third Wrap Indicator** – Rated capacity limiter color display visually and audibly warns the operator when the wire rope is on the first/bottom layer and when the wire rope is down to the last three wraps.

Auxiliary winch can be removed by cranes’ counterweight removal system.

## ■ Counterweight

**Standard** – Total of 112,435 lb (51 000kg) of total counterweight consisting of auxiliary winch or 2,205 lb (1 000kg) counterweight and six hydraulically removable counterweights. Assembled and disassembled by hydraulic cylinders controlled from the operator’s cab with capacities for:

- 0 lb (0kg) counterweight
- 28,660 lb (13 000kg) counterweight
- 55,115 lb (25 000kg) counterweight
- 81,570 lb (37 000kg) counterweight
- 112,435 lb (51 000kg) counterweight

Low speed jobsite travel is offered for these counterweight configurations and a boom dolly or boom trailer may be required for on–highway travel.

\* Overall width of the crane increases to 15 ft 1 in (4.6m) for this counterweight configuration.

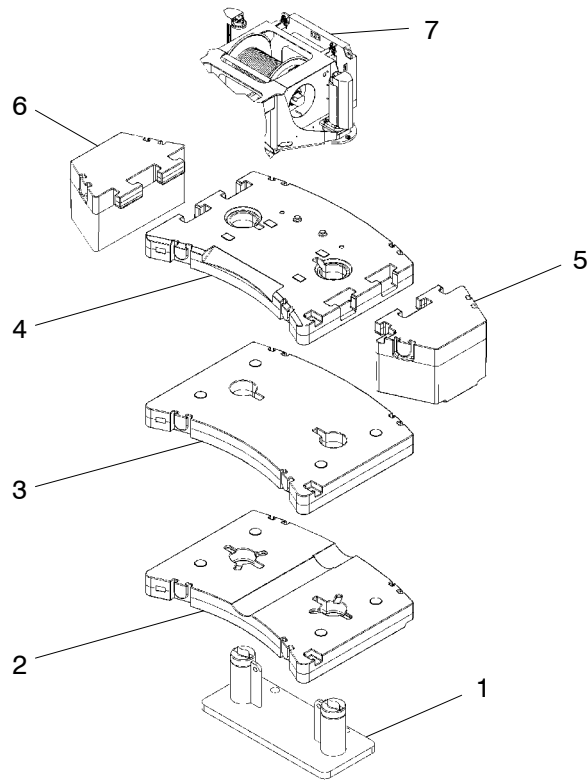

Counterweight Modules			1	2	3	4	5	6	7*
			3,968 lb (1,800kg) tray	22,487 lb (10,200kg) piece	26,455 lb (12,000kg) piece	26,455 lb (12,000kg) piece	15,432 lb (7,000kg) piece	15,432 lb (7,000kg) piece	2,204 lb (1,000kg) top*
Counterweight Usage Configurations	Standard	0 lb (0kg)							
		28,660 lb (13,000kg)	X	X					X
		55,115 lb (25,000kg)	X	X	X				X
		81,570 lb (37,000kg)	X	X	X	X			X
		112,435 lb (51,000kg)	X	X	X	X	X	X	X

\* Auxiliary winch replaces this counterweight for a two-drum configuration.

# Carrier

## ■ General

- 9 ft 10 in (3.0m) wide with 20.5R25 tires
- 27 ft 10 in (8.5m) wheelbase (centerline of first axle to centerline of fifth axle)
- **Frame** – Box-type, torsion resistant, welded construction made of high tensile steel. Equipped with front and rear towing and tie-down lugs, tow connections, and access ladders.

## ■ Outriggers

**Boxes** – Two double box, front and rear welded to the carrier frame

**Beams and Jacks** – Four dual stage beams with Confined Area Lifting Capacities (CALC) provide selectable outrigger extensions of full and intermediate positions. Jacks with integral check valves, hydraulically controlled from the operator's cab and on both sides of carrier. Automatic leveling.

**Pontoons** – Four lightweight, stow'n go, 23.6" (60.0cm) square nylon pontoons with a contact area of 558 in<sup>2</sup> (3 600.0cm<sup>2</sup>) can be stored for road travel under the outrigger boxes.

**Main Jack Reaction** – 213,568 lb (950.0kN) force and 383 psi (2 640.7kPa) ground bearing pressure

## ■ Steering and Axles

- ZF-Servocom dual circuit system provides hydraulic assisted steering with a mechanical link between the steering wheel and two front axles. The two rear axles steer hydraulically and operation is based on primary and auxiliary steering modes.

**Primary Steering Mode** – Axles 4 and 5 will automatically steer in combination with axles 1 and 2 based on travel speed:

Primary			
Speed	Less than 15.5 mph (25km/h)	15.5–31.0 mph (25–50km/h)	Greater than 31.0 mph (50km/h)
Axle 1	Steered	Steered	Steered
Axle 2	Steered	Steered	Steered
Axle 3	Fixed (Lifted or Down)	Fixed (Lifted or Down)	Fixed (Lifted or Down)
Axle 4	Steered	Locked	Locked
Axle 5	Steered	Steered	Locked

**Auxiliary Steering Modes** – Five independent modes consisting of:

- **Independent Front:** Axles 1 and 2 (Axle 3 is lifted)
- **Combination:** Axles 1, 2, 4, and 5 (Axle 3 is lifted)
- **Crab:** Axles 1, 2, 4, and 5 (Axle 3 is lifted)
- **Independent Rear:** Axles 4 and 5 (Axle 3 is lifted)
- **Drive Away From Walls:** Temporary crab mode (Axle 3 is lifted)

The front, combination, and crab steering modes are controlled from the steering wheel and are selected by controls in the driver's cab. Momentary switches located in the driver's cab control the rear steering mode. Limited to 3rd gear travel.

- **Emergency Steering** – A pump is flange-mounted to the transfer box that provides hydraulic pressure to the steering circuit as long as the crane is in motion above 1.85 mph (3km/h).
- **Drive** – Two modes: 10 x 6 for highway travel: 1st, 4th, and 5th axles are driven. 10 x 8 for job-site travel: 1st, 2nd, 4th, and 5th axle are driven.
- **Axle 1** – Steered, driven for job-site travel
- **Axle 2** – Steered, driven
- **Axle 3** – Non steered, non driven, lift system
- **Axle 4** – Steered, driven
- **Axle 5** – Steered, driven
- **Inter-Axle Differential Lock** – Traction adding device that locks axles 1 and 2 with axles 4 and 5. Operated by a switch from the carrier cab.
- **Transverse (Cross-Axle) Differential Locks** – Traction adding device that locks differentials within axles 1, 2, 4, and 5. Operated by a switch from the carrier cab with a 10 second timer.

## ■ Suspension

Hydro-pneumatic, lockable with level adjustment and automatic ride height leveling. All axles have longitudinal and transverse trailing arms with leveling adjustment and locked cylinders. The carrier can be tilted laterally and longitudinally by controls in the carrier cab that adjust each individual suspension cylinder.

- Cylinder stroke: –4.6 in (118mm) / +6.2 in (158mm)

**Third Axle Lift System** – Axle 3 lifts independently for highway travel and job-site travel applications. Operated by a switch from the carrier cab.

**Third Axle Boost** – Axle 3 is presettable to a specific load when the boom is over the front. Boost range is between 17,700 lb (8 028.6kg) and 30,800 lb (13 970.6kg).

## ■ Ground Control Outrigger/Suspension Controls

Environmentally sealed and ergonomically positioned, control stations located on the left and right side of the carrier with controls and indicators for crane operations including:

- Starts and stops carrier engine
- Throttles carrier engine up and down
- Suspension operation including:
  - Raise and lower suspension on outriggers
  - Automatic ride height leveling on tires
- Outrigger operation including:
  - Extends and retracts two beams together
  - Extends and retracts all jacks together
  - Automatic leveling on outriggers
- Outrigger lighting
- Monitor's contrast and brightness
- Electronic bubble level
- Levelness or inclination
- One position swing lock engagement indicator
- Outrigger force readout – optional

## ■ Tires and Wheels

**Standard** – Ten (single) 20.5R25 tires on steel disc wheels.

**Optional** – Ten (single) 16.00R25 tires on steel disc wheels.

- Tire inflation kit
- Spare tires and wheels – optional

## ■ Brakes

**Service** – Full air brakes on all wheel ends. Dual circuit compressed air system with air dryer.

**Parking/Emergency** – Spring loaded type, acting on 2nd, 4th, and 5th axles

**Intarder** – Hydrodynamic driveline brake that is integral to the transmission. Operated by a switch from the carrier cab.

## ■ Central Lubrication System

Automated lubrication unit that injects grease into the steering gear arms, steering knuckles, and suspension cylinders. Operated by a switch from the carrier's cab.

## ■ Electrical

Two batteries provide 24-volt operation and starting. CAN bus wiring and components, and integral self-test CSS (Control & Service System).

### Lights

- Front lighting includes two main headlights, two high beam lights, two fog lights, two directional indicators, and two parking lights
- Rear lighting includes two rear combination panels each with directional indicator, parking light, brake light, fog light, reversing light, and license plate light
- Other equipment includes hazard/warning system, cab light, instrument panel light, signal horn, and two amber rotating beacons on cab roof
- Four lights to illuminate the outriggers

## ■ Engine

Specification	Mercedes Benz OM 502 LA
Numbers of cylinders	8
Cycle	4
Bore and Stroke: inch ( <i>mm</i> )	5.12 x 5.91 ( <i>130x150</i> )
Piston Displacement: in <sup>3</sup> ( <i>cm<sup>3</sup></i> )	972.04 ( <i>15 929</i> )
Max. Brake Horsepower: hp ( <i>kW</i> )	523 ( <i>390</i> ) @ 1,800 rpm
Peak Torque: ft lb ( <i>Nm</i> )	1,770 ( <i>2 400</i> ) @ 1,300 rpm
Alternator: volts – amps	24 – 100
Crankcase Capacity: qt ( <i>L</i> )	42.27 ( <i>40</i> )
<ul style="list-style-type: none"> <li>• Cruise control</li> <li>• Engine exhaust brake</li> <li>• Engine compression brake</li> <li>• Two thermostatically controlled, hydraulically driven radiator fans</li> </ul>	

## ■ Transmission

**Automated** – ZF AS-TRONIC (no clutch pedal) automated manual transmission with 16 forward gears and 2 reverse gears

**Auxiliary** – Transfer case with high/low range

## ■ Fuel Tank

One 140 gal (*530L*) capacity tank

## ■ Hydraulic System

### Main Pumps

- One variable displacement piston pump for the front steering circuit 1, cooling fans, suspension, and outriggers
- One fixed displacement piston pump for front steering circuit 2
- Two fixed displacement gear pumps for rear steering
- One fixed displacement piston pump for emergency steering
- The carrier engine powers the pumps. Combined pump capacity of 73.7 gpm (*279Lpm*).

**Hydraulic Reservoir** – 76.6 gal (*290L*) capacity equipped with sight level gauge. Diffusers built in for deaeration.

**Filtration** – Two 12 micron, full flow, line filter in the control circuit. All oil is filtered prior to return to sump tank. Accessible for easy filter replacement.

## ■ Cab and Controls

**Cab** – Fully enclosed, two person full width cab of composite structure with acoustical insulation. Equipped with:

- Tinted and tempered glass windows
- Windshield wiper and washer
- Slide side windows of hardened glass
- Six way adjustable and air suspended driver and passenger seats with integrated three point safety belts and headrests
- Two heated and electrically adjustable rear–view mirrors
- One heated wide angle mirror and additional turn mirror
- Engine dependent warm–water heater with defroster nozzles for windshield and cab floor
- AM/FM radio with single disc CD player
- Adjustable sun visor
- Dome light
- 12 volt and 24 volt connection
- Air conditioning
- Fire extinguisher

**Cab Instrumentation** – Ergonomically positioned analog instrumentation for driving including:

- Speedometer with odometer
- Transmission mode, gear indication, and travel direction
- Engine coolant temperature
- Fuel level
- Tachometer with hourmeter

**Dash Mounted** – Controls and indicators for:

- Battery main shutoff
- Carrier throttle (0 to 1,200 rpm)
- Carrier lighting
- Auxiliary transmission high/low range
- 10x8 drive, inter–axle lock, and transverse differential lock
- Suspension operation, automatic leveling, and lock
- Cruise and intarder activation
- Mirror heating
- Warning lamps
- Engine/gearbox malfunction with audible alarm
- Service and park brake indication
- Steering system malfunction with audible alarm

**Cockpit Multi–Vision (CMV) Display** – Ergonomically positioned on the driver's dash panel, digital instrumentation and indicators for crane operations including:

- Front and rear air pressure
- Air cleaner and hydraulic oil filter replacement
- Low engine oil and coolant
- Steering system malfunction
- Emergency steering activation
- CAN–BUS diagnostics
- Sensor fault
- Low voltage
- Tachometer fault
- Low fuel
- Suspension lifted and locked
- Auxiliary transmission high/low range
- Suspension leveled
- High beam headlights

- Third axle lifted
- Rear fog light activation
- 10x8 drive, inter–axle lock, and transverse differential lock
- One position swing lock engagement
- Intarder activation
- Axle oscillation activation
- Central lubrication activation
- Boom raised out of the boom rest
- Display contrast and brightness readout
- Crane service diagnostics readouts
- Electronic bubble level
- Axle loadings readouts
- Steering modes

**Center Console** – Controls and indicators for:

- Heating and air conditioning controls
- Transmission gear shifting
- Auxiliary steering controls
- Rear axle locking switch
- Mirror adjustments
- Park brake

**Steering Column** – Controls for:

- Carrier ignition
- Warning horn
- Turn indicators
- High beam headlights
- Steer wheel adjustments
- Cruise and intarder controls
- Windshield wipers and washers

**Foot Controls** – Controls for:

- Carrier service brakes
- Engine throttle

## ■ Additional Equipment

**Standard:**

- Pneumatic and electrical quick disconnect connectors mounted on the rear bumper for boom dolly brakes and lights
- Emergency function overrides
- Aluminum full deck fenders and ladders
- Hook block and ball bumper tie backs
- Left and right side carrier storage boxes
- Hook ball storage
- Folding ladder (stowed under the carrier cab)
- Handling slings
- Mud flaps
- Tool box with tools
- Grease gun
- First aid kit
- Tire inflation system
- Battery jumper cables

## Carrier Speeds and Gradeability

ZF Astronic		Speed				Gradeability (@ Peak Torque Except Creep @ Idle)	
		High Range (0.800)		Low Range (1.836)		High Range (0.800)	Low Range (1.836)
Gear	Ratio	mph	km/h	mph	km/h	% Grade	
16th	0.83	52.8	85.0	26.1	42.0	1	2
15th	1.00	49.7	80.0	21.7	35.0	2	3
14th	1.18	42.3	68.0	18.6	30.0	3	3
13th	1.43	34.8	56.0	14.9	24.0	3	4
12th	1.73	28.6	46.0	12.4	20.0	4	5
11th	2.09	23.6	38.0	10.6	17.0	6	7
10th	2.56	19.3	31.0	8.7	14.0	7	8
9th	3.09	16.2	26.0	6.8	11.0	9	11
8th	3.78	13.0	21.0	5.6	9.0	11	13
7th	4.57	11.2	18.0	5.0	8.0	14	16
6th	5.39	9.3	15.0	4.3	7.0	16	19
5th	6.52	7.5	12.0	3.1	5.0	20	24
4th	7.89	6.2	10.0	2.5	4.0	25	30
3rd	9.54	5.0	8.0	2.5	4.0	31	37
2nd	11.68	4.3	7.0	1.9	3.0	39	47
1st	14.12	3.7	6.0	1.9	3.0	47	61
Reverse 1 (Low)	13.07	3.7	6.0	1.9	3.0	45	55
Reverse 2 (High)	10.81	4.3	7.0	1.9	3.0	36	43
1st @ 800 rpm	14.12	1.4	2.0	0.6	1.0	N/A	N/A
Reverse 1 (Low) @ 800 rpm	13.07	1.4	2.0	0.6	1.0	N/A	N/A
Reverse 2 (High) @ 800 rpm	10.81	1.4	2.0	0.6	1.0	N/A	N/A

Based on a 132,277.4 lb (60 000kg) gross vehicle weight with 16.00R25 and 20.5R25 tires

## Axle Loads – English

Base crane with full tank of fuel and no counterweight	Gross Vehicle Weight <sup>(1)</sup>	Axle 1	Axle 2	Axle 3*	Axle 4	Axle 5
	lb	lb	lb	lb	lb	lb
	127,983	25,271	25,456	25,500	25,963	25,793
Third axle lifted	---	6,670	6,670	-25,500	6,080	6,080
Driver in carrier cab	250	177	177	0	-52	-52
16.00R25 tires (instead of standard)	-1,036	-259	-259	0	-259	-259
Auxiliary winch with 820 ft if 0.83 in diameter rope	3,043	-882	-882	0	2,403	2,403
[7] counterweight 2,205 lb on upper – replaces auxiliary winch	2,205	-580	-580	0	1,682	1,682
[5&6] counterweight 30,865 lb on upper – requires counterweight [4]	30,265	-6,781	-6,781	0	21,913	21,913
[4] counterweight 26,455 lb on upper– requires counterweight [1]	26,301	-5,893	-5,893	0	19,043	19,043
[3] counterweight 26,455 lb on upper – requires counterweight [1]	26,301	-5,893	-5,893	0	19,043	19,043
[2] counterweight 22,487 lb on upper – requires counterweight [1]	22,179	-4,927	-4,927	0	16,016	16,016
[1] counterweight 3,968 lb on upper	4,123	-922	-922	0	2,984	2,984
17.7–43.3 ft offsettable, two piece lattice fly (stowed)	3,351	1,739	1,739	0	-64	-64
Auxiliary lifting sheave (erected)	187	173	173	0	-79	-79
88.2 ton 5 sheave quick–reeve hook block with safety latch (stowed at front bumper)	1,830	1,600	1,600	0	-685	-685
88.2 ton 5 sheave quick–reeve hook block with safety latch (stowed at boom head)	1,830	1,683	1,683	0	-768	-768
27.6 ton 1 sheave quick–reeve hook block with safety latch (stowed at front bumper)	660	577	577	0	-247	-247
27.6 ton 1 sheave quick–reeve hook block with safety latch (stowed at boom head)	660	607	607	0	-277	-277
11.0 ton swivel hook ball with safety latch (stowed in carrier storage)	661	-102	-102	0	433	433
11.0 ton swivel hook ball with safety latch (stowed at front bumper)	661	578	578	0	-248	-248
11.0 ton swivel hook ball with safety latch (stowed at boom head)	661	624	624	0	-293	-293

Counterweight Load Transfer	Axle 1	Axle 2	Axle 3*	Axle 4	Axle 5
	lb	lb	lb	lb	lb
Transfer [6] counterweight 14,110 lb to carrier deck	15,845	15,845	0	-15,845	-15,845
Transfer [7] counterweight 5,071 lb to carrier deck	15,845	15,845	0	-15,845	-15,845
Transfer [8] counterweight 6,834 lb to carrier deck	13,277	13,277	0	-13,277	-13,277
Transfer [9] counterweight 2,425 lb to carrier deck	2,481	2,481	0	-2,481	-2,481

<sup>(1)</sup> Adjust gross vehicle weight and axle loading according to component weight. All weights are  $\pm 3\%$ .

\*Axle 3 is presettable to a specific loading when boom is over the front. Boost range is between 17,700 lb to 30,800 lb.

Tire	Maximum Axle Load @ 50 mph Average Speed
20.5R25	26,015 lb
16.00R25	24,471 lb



## Axle Loads – Metric

Base crane with full tank of fuel and no counterweight	Gross Vehicle Weight <sup>(1)</sup>	Axle 1	Axle 2	Axle 3*	Axle 4	Axle 5
	kg	kg	kg	kg	kg	kg
	58 052	11 463	11 547	11 567	11 776	11 699
Third axle lifted	---	3 025	3 025	-11 567	2 758	2 758
Driver in carrier cab	113	80	80	0	-24	-24
16.00R25 tires (instead of standard)	-470	-117	-117	0	-117	-117
Auxiliary winch with 250m if 22mm diameter rope	1 380	-400	-400	0	1 090	1 090
[7] counterweight 1 000kg on upper – replaces auxiliary winch	1 000	-263	-263	0	763	763
[5&6] counterweight 14 000kg on upper – requires counterweight [4]	13 728	-3 076	-3 076	0	9 940	9 940
[4] counterweight 12 000kg on upper – requires counterweight [1]	11 930	-2 673	-2 673	0	8 638	8 638
[3] counterweight 12 000kg on upper – requires counterweight [1]	11 930	-2 673	-2 673	0	8 638	8 638
[2] counterweight 10 200kg on upper – requires counterweight [1]	10 060	-2 235	-2 235	0	7 265	7 265
[1] counterweight 1 800kg on upper	1 870	-418	-418	0	1 354	1 354
5.4 – 13.2m offsettable, two piece lattice fly (stowed)	1 520	789	789	0	-29	-29
Auxiliary lifting sheave (erected)	85	78	78	0	-36	-36
80 mt 5 sheave quick-reeve hook block with safety latch (stowed at front bumper)	830	726	726	0	-311	-311
80 mt 5 sheave quick-reeve hook block with safety latch (stowed at boom head)	830	763	763	0	-348	-348
25 mt 1 sheave quick-reeve hook block with safety latch (stowed at front bumper)	300	262	262	0	-112	-112
25 mt 1 sheave quick-reeve hook block with safety latch (stowed at boom head)	300	275	275	0	-125	-125
10 mt swivel hook ball with safety latch (stowed in carrier storage)	300	-46	-46	0	196	196
10 mt swivel hook ball with safety latch (stowed at front bumper)	300	262	262	0	-112	-112
10 mt swivel hook ball with safety latch (stowed at boom head)	300	283	283	0	-133	-133

Counterweight Load Transfer	Axle 1	Axle 2	Axle 3*	Axle 4	Axle 5
	kg	kg	kg	kg	kg
Transfer [6] counterweight 6 400kg to carrier deck	7 187	7 187	0	-7 187	-7 187
Transfer [7] counterweight 2 300kg to carrier deck	7 187	7 187	0	-7 187	-7 187
Transfer [8] counterweight 3 100kg to carrier deck	6 022	6 022	0	-6 022	-6 022
Transfer [9] counterweight 1 100kg to carrier deck	1 125	1 125	0	-1 125	-1 125

(<sup>1</sup>) Adjust gross vehicle weight and axle loading according to component weight. All weights are  $\pm 3\%$ .

\*Axle 3 is presettable to a specific loading when boom is over the front. Boost range is between 8 028.6kg to 13 970.6kg.

Tire	Maximum Axle Load @ 80km/h Average Speed
20.5R25	11 800kg
16.00R25	11 100kg

## Axle Loads with 2 – Axle or 3 – Axle Boom Dolly (3rd Axle Down) – English

Base crane with full tank of fuel and no counterweight	Gross Vehicle Weight <sup>(1)</sup>	Axle 1	Axle 2	Axle 3	Axle 4	Axle 5	Dolly
	lb	lb	lb	lb	lb	lb	lb
	127,983	21,491	21,676	19,762	20,409	20,239	24,406
Driver in carrier cab	250	188	188	-42	-42	-42	0
16.00R25 tires (instead of standard)	-1,036	-204	-204	-209	-209	-209	0
Auxiliary winch with 820 ft if 0.83 in diameter rope	3,043	1,315	1,315	137	137	137	0
[7] counterweight 2,205 lb on upper – replaces auxiliary winch	2,205	882	882	147	147	147	0
[5&6] counterweight 30,865 lb on upper – requires counterweight [4]	30,265	10,675	10,675	2,972	2,972	2,972	0
[4] counterweight 26,455 lb on upper – requires counterweight [1]	26,301	9,277	9,277	2,583	2,583	2,583	0
[3] counterweight 26,455 lb on upper – requires counterweight [1]	26,301	9,277	9,277	2,583	2,583	2,583	0
[2] counterweight 22,487 lb on upper – requires counterweight [1]	22,179	7,771	7,771	2,212	2,212	2,212	0
[1] counterweight 3,968 lb on upper	4,123	1,453	1,453	406	406	406	0
17.7 – 43.3 ft offsettable, two piece lattice fly (stowed)	3,351	198	198	145	145	145	2,519
Auxiliary lifting sheave (erected)	187	-15	-15	-11	-11	-11	251
88.2 ton 5 sheave quick – reeve hook block with safety latch (stowed at boom head)	1,830	-92	-92	-67	-67	-67	2,216
88.2 ton 5 sheave quick – reeve hook block with safety latch (stowed on dolly)	1,830	0	0	0	0	0	1,830
27.6 ton 1 sheave quick – reeve hook block with safety latch (stowed at boom head)	660	-33	-33	-24	-24	-24	799
27.6 ton 1 sheave quick – reeve hook block with safety latch (stowed on dolly)	660	0	0	0	0	0	660
11.0 ton swivel hook ball with safety latch (stowed in carrier storage)	661	-194	-194	350	350	350	0
11.0 ton swivel hook ball with safety latch (stowed at boom head)	661	-38	-38	-27	-27	-27	819
11.0 ton swivel hook ball with safety latch (stowed on dolly)	661	0	0	0	0	0	661
2 – axle boom dolly	5,500	0	0	0	0	0	5,500
3 – axle boom dolly	8,800	0	0	0	0	0	8,800

<sup>(1)</sup> Adjust gross vehicle weight and axle loading according to component weight. All weights are  $\pm 3\%$ .

Tire	Maximum Axle Load @ 50 mph Average Speed
20.5R25	26,015 lb
16.00R25	24,471 lb

## Axle Loads with 2 – Axle or 3 – Axle Boom Dolly (3rd Axle Down) – Metric

Base crane with full tank of fuel and no counterweight	Gross Vehicle Weight <sup>(1)</sup>	Axle 1	Axle 2	Axle 3*	Axle 4	Axle 5	Dolly
	kg	kg	kg	kg	kg	kg	kg
	58 052	9 748	9 832	8 964	9 257	9 180	11 070
Driver in carrier cab	113	85	85	-19	-19	-19	0
16.00R25 tires (instead of standard)	-470	-93	-93	-95	-95	-95	0
Auxiliary winch with 250m if 22mm diameter rope	1 380	597	597	62	62	62	0
[7] counterweight 1 000kg on upper – replaces auxiliary winch	1 000	400	400	67	67	67	0
[5&6] counterweight 14 000kg on upper – requires counterweight [4]	13 728	4 842	4 842	1 348	1 348	1 348	0
[4] counterweight 12 000kg on upper – requires counterweight [1]	11 930	4 208	4 208	1 172	1 172	1 172	0
[3] counterweight 12 000kg on upper – requires counterweight [1]	11 930	4 208	4 208	1 172	1 172	1 172	0
[2] counterweight 10 200kg on upper – requires counterweight [1]	10 060	3 525	3 525	1 003	1 003	1 003	0
[1] counterweight 1 800kg on upper	1 870	659	659	184	184	184	0
5.4 – 13.2m offsettable, two piece lattice fly (stowed)	1 520	90	90	66	66	66	1 143
Auxiliary lifting sheave (erected)	85	-7	-7	-5	-5	-5	114
80 mt 5 sheave quick-reeve hook block with safety latch (stowed at boom head)	830	-42	-42	-30	-30	-30	1 005
80 mt 5 sheave quick-reeve hook block with safety latch (stowed on dolly)	830	0	0	0	0	0	830
25 mt 1 sheave quick-reeve hook block with safety latch (stowed at boom head)	300	-15	-15	-11	-11	-11	363
25 mt 1 sheave quick-reeve hook block with safety latch (stowed on dolly)	300	0	0	0	0	0	300
10 mt swivel hook ball with safety latch (stowed in carrier storage)	300	-88	-88	159	159	159	0
10 mt swivel hook ball with safety latch (stowed at boom head)	300	-17	-17	-12	-12	-12	371
10 mt swivel hook ball with safety latch (stowed on dolly)	300	0	0	0	0	0	300
2-axle boom dolly	2 495	0	0	0	0	0	2 495
3-axle boom dolly	3 992	0	0	0	0	0	3 992

(1) Adjust gross vehicle weight and axle loading according to component weight. All weights are  $\pm 3\%$ .

Tire	Maximum Axle Load @ 80km/h Average Speed
20.5R25	11 800kg
16.00R25	11 100kg

## Axle Loads with 2 – Axle or 3 – Axle Boom Dolly (3rd Axle Lifted) – English

Base crane with full tank of fuel and no counterweight	Gross Vehicle Weight <sup>(1)</sup>	Axle 1	Axle 2	Axle 3	Axle 4	Axle 5	Dolly
	lb	lb	lb	lb	lb	lb	lb
	127,983	26,660	26,845	0	25,121	24,951	24,406
Driver in carrier cab	250	177	177	0	-52	-52	0
16.00R25 tires (instead of standard)	-1,036	-259	-259	0	-259	-259	0
Auxiliary winch with 820 ft if 0.83 in diameter rope	3,043	1,351	1,351	0	170	170	0
[7] counterweight 2,205 lb on upper – replaces auxiliary winch	2,205	920	920	0	182	182	0
[5&6] counterweight 30,865 lb on upper – requires counterweight [4]	30,265	11,452	11,452	0	3,680	3,680	0
[4] counterweight 26,455 lb on upper – requires counterweight [1]	26,301	9,952	9,952	0	3,198	3,198	0
[3] counterweight 26,455 lb on upper – requires counterweight [1]	26,301	9,952	9,952	0	3,198	3,198	0
[2] counterweight 22,487 lb on upper – requires counterweight [1]	22,179	8,350	8,350	0	2,739	2,739	0
[1] counterweight 3,968 lb on upper	4,123	1,559	1,559	0	503	503	0
17.7 – 43.3 ft offsettable, two piece lattice fly (stowed)	3,351	236	236	0	180	180	2,519
Auxiliary lifting sheave (erected)	187	-18	-18	0	-14	-14	251
88.2 ton 5 sheave quick – reeve hook block with safety latch (stowed at boom head)	1,830	-110	-110	0	-83	-83	2,216
88.2 ton 5 sheave quick – reeve hook block with safety latch (stowed on dolly)	1,830	0	0	0	0	0	1,830
27.6 ton 1 sheave quick – reeve hook block with safety latch (stowed at boom head)	660	-39	-39	0	-30	-30	799
27.6 ton 1 sheave quick – reeve hook block with safety latch (stowed on dolly)	660	0	0	0	0	0	660
11.0 ton swivel hook ball with safety latch (stowed in carrier storage)	661	-102	-102	0	433	433	0
11.0 ton swivel hook ball with safety latch (stowed at boom head)	661	-45	-45	0	-34	-34	819
11.0 ton swivel hook ball with safety latch (stowed on dolly)	661	0	0	0	0	0	661
2 – axle boom dolly	5,500	0	0	0	0	0	5,500
3 – axle boom dolly	8,800	0	0	0	0	0	8,800

<sup>(1)</sup> Adjust gross vehicle weight and axle loading according to component weight. All weights are  $\pm 3\%$ .

Tire	Maximum Axle Load @ 50 mph Average Speed
20.5R25	26,015 lb
16.00R25	24,471 lb

## Axle Loads with 2 – Axle or 3 – Axle Boom Dolly (3rd Axle Lifted) – Metric

Base crane with full tank of fuel and no counterweight	Gross Vehicle Weight <sup>(1)</sup>	Axle 1	Axle 2	Axle 3*	Axle 4	Axle 5	Dolly
	kg	kg	kg	kg	kg	kg	kg
	58 053	12 092	12 177	0	11 395	11 318	11 071
Driver in carrier cab	113	80	80	0	-24	-24	0
16.00R25 tires (instead of standard)	-470	-117	-117	0	-117	-117	0
Auxiliary winch with 250m if 22mm diameter rope	1 380	613	613	0	77	77	0
[7] counterweight 1 000kg on upper – replaces auxiliary winch	1 000	417	417	0	83	83	0
[5&6] counterweight 14 000kg on upper – requires counterweight [4]	13 728	5 195	5 195	0	1 669	1 669	0
[4] counterweight 12 000kg on upper – requires counterweight [1]	11 930	4 514	4 514	0	1 451	1 451	0
[3] counterweight 12 000kg on upper – requires counterweight [1]	11 930	4 514	4 514	0	1 451	1 451	0
[2] counterweight 10 200kg on upper – requires counterweight [1]	10 060	3 787	3 787	0	1 242	1 242	0
[1] counterweight 1 800kg on upper	1 870	707	707	0	228	228	0
5.4 – 13.2m offsettable, two piece lattice fly (stowed)	1 520	107	107	0	82	82	1 143
Auxiliary lifting sheave (erected)	85	-8	-8	0	-6	-6	114
80 mt 5 sheave quick-reeve hook block with safety latch (stowed at boom head)	830	-50	-50	0	-38	-38	1 005
80 mt 5 sheave quick-reeve hook block with safety latch (stowed on dolly)	830	0	0	0	0	0	830
25 mt 1 sheave quick-reeve hook block with safety latch (stowed at boom head)	299	-18	-18	0	14	14	362
25 mt 1 sheave quick-reeve hook block with safety latch (stowed on dolly)	299	0	0	0	0	0	299
10 mt swivel hook ball with safety latch (stowed in carrier storage)	300	-46	-46	0	196	196	0
10 mt swivel hook ball with safety latch (stowed at boom head)	300	-20	-20	0	-15	-15	371
10 mt swivel hook ball with safety latch (stowed on dolly)	300	0	0	0	0	0	300
2-axle boom dolly	2 495	0	0	0	0	0	2 495
3-axle boom dolly	3 992	0	0	0	0	0	3 992

(1) Adjust gross vehicle weight and axle loading according to component weight. All weights are  $\pm 3\%$ .

Tire	Maximum Axle Load @ 80km/h Average Speed
20.5R25	11 800kg
16.00R25	11 100kg

# General Dimensions

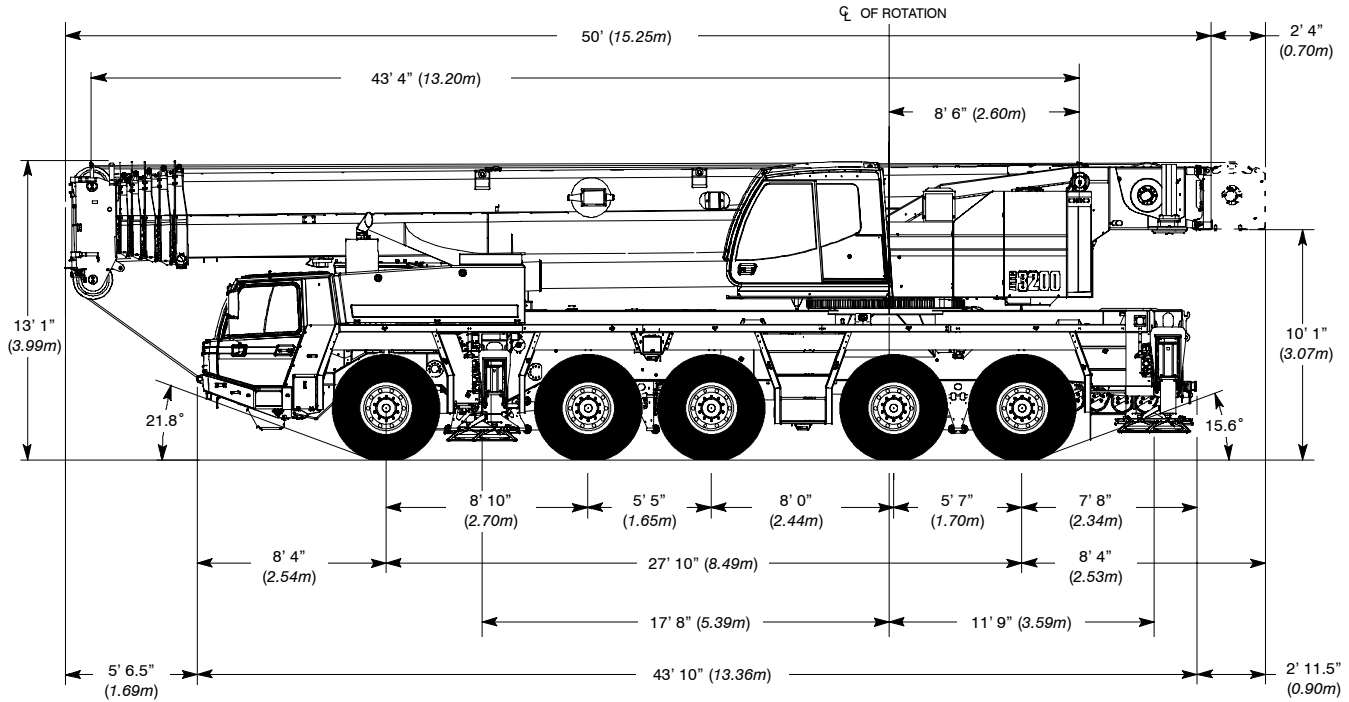

Turning Radius	20.5R25		16.00R25	
	English	Metric	English	Metric
Wall to wall over carrier	36' 0"	11.0m	35' 9"	10.9m
Wall to wall over boom	38' 4"	11.7m	38' 1"	11.6m
Wall to wall over boom attachment	40' 7"	12.4m	40' 4"	12.3m
Curb to curb	32' 2"	9.80m	31' 11"	9.72m
Centerline of tire	31' 5"	9.6m	31' 2"	9.5m

Tail Swing	English	Metric
With auxiliary winch	16' 8"	5.1m
Without auxiliary winch	14' 5"	4.4m

Overall Width	English	Metric
With up to 81,570 lb (37 000kg) counterweight	9' 10"	3.0m
With 112,435 lb (51 000kg) counterweight	15' 1"	4.6m

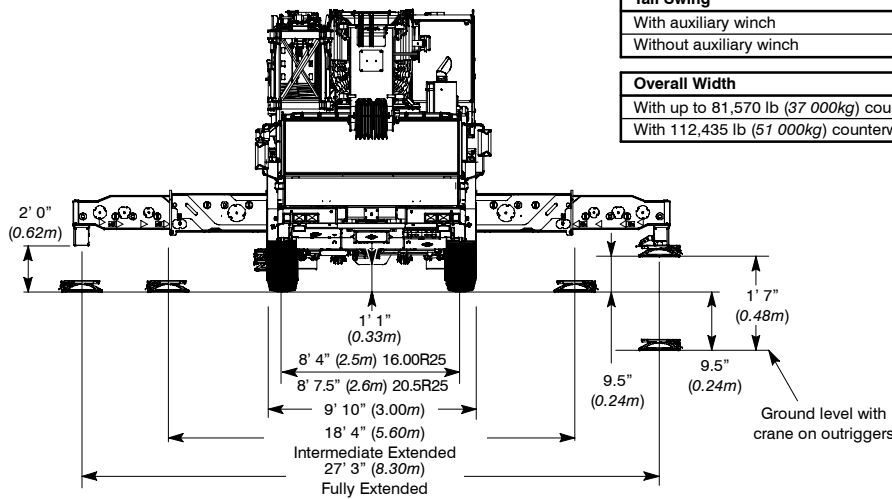

Not To Scale

# Working Range Diagram

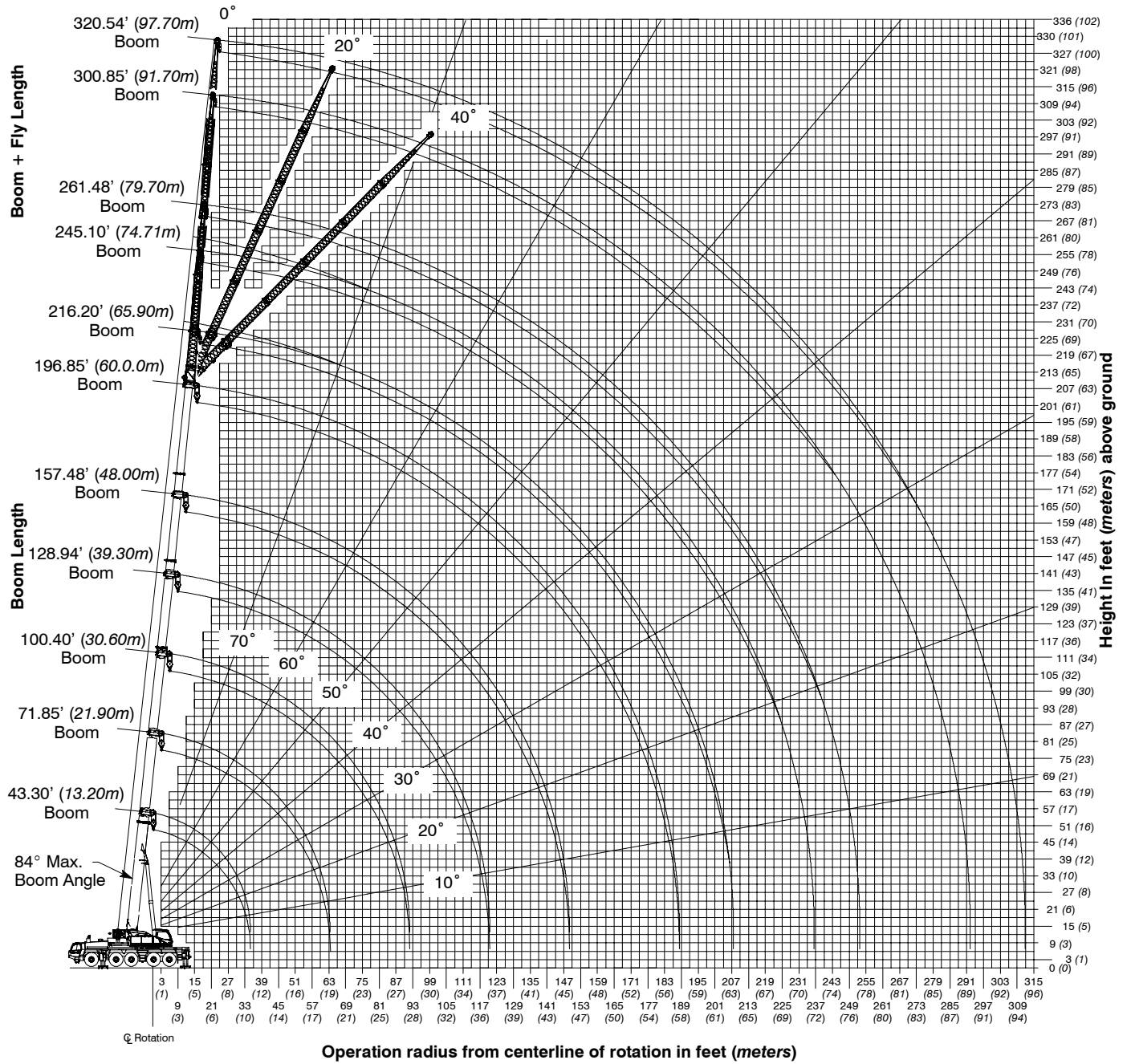

# Boom Extend Modes

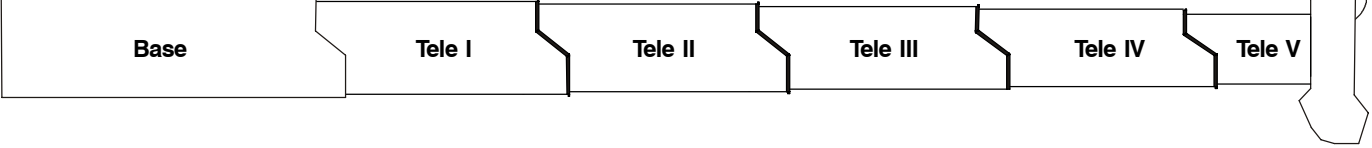

Boom Length		Sections Length				
ft	m	Tele I	Tele II	Tele III	Tele IV	Tele V
196.9	60.0	100%	100%	100%	100%	100%
186.0	56.7	93%	93%	93%	93%	93%
171.9	52.4	46%	93%	93%	93%	93%
		93%	93%	93%	93%	46%
157.5	48.0	0	93%	93%	93%	93%
		93%	93%	93%	46%	46%
		46%	93%	93%	93%	46%
143.4	43.7	0%	46%	93%	93%	93%
		46%	46%	46%	93%	93%
		93%	93%	46%	46%	46%
128.9	39.3	0%	0%	93%	93%	93%
		93%	46%	46%	46%	46%
		46%	46%	46%	46%	93%
114.8	35.0	0%	0%	46%	93%	93%
		46%	46%	46%	46%	46%
		46%	46%	46%	46%	0%
100.4	30.6	0%	0%	0%	93%	93%
		0%	0%	46%	46%	93%
		93%	46%	46%	0%	0%
86.3	26.3	0%	0%	0%	46%	93%
		0%	0%	46%	46%	46%
		46%	46%	46%	0%	0%
86.3	21.9	0%	0%	0%	0%	93%
		0%	0%	0%	46%	46%
		46%	46%	0%	0%	0%
		0%	46%	46%	0%	0%
57.7	17.6	0%	0%	0%	0%	46%
		0%	46%	0%	0%	0%
43.3	13.2	0%	0%	0%	0%	0%



# Main Boom Lift Capacity Charts

**112,435 lb Counterweight – Fully Extended Outriggers – 360° Rotation**  
**(All Capacities Are Listed In Thousand Pounds)**

Radius (ft)	Boom Length (ft)												Radius (ft)	
	43.3 (1)	43.3	57.7	71.9	86.3	100.4	114.8	128.9	143.3	157.5	171.9	186.0		196.9
9	400.0*													9
10	350.5*	307.5*	264.5*	255.0*	196.5									10
12	322.5*	279.0*	264.5*	255.0*	196.5	162.5								12
14	294.5*	254.5*	255.0*	250.0*	196.5	156.0								14
16	270.0*	228.5	229.0	228.5	196.5	145.5	121.5							16
18	243.0	209.5	210.0	209.5	196.5	136.5	119.5							18
20	216.5	193.5	194.0	193.0	194.0	128.0	117.0	91.3	73.6					20
25	168.5	161.0	161.5	164.5	163.5	111.0	102.0	91.3	73.6	59.3				25
30	134.5	134.5	136.5	138.0	136.5	97.5	95.5	83.8	73.3	59.3	47.6	37.5		30
35			115.0	117.0	115.5	87.1	88.8	75.3	68.3	58.0	47.0	37.5	30.9	35
40			99.8	101.0	99.8	78.0	82.2	68.0	61.7	54.9	45.7	37.4	30.9	40
45			87.4	88.5	87.4	71.9	76.5	62.0	56.5	51.2	42.9	36.3	30.9	45
50				79.4	78.0	66.7	71.4	56.7	51.9	47.9	40.1	34.4	30.9	50
55				70.3	68.8	62.0	67.6	52.2	47.8	44.6	37.7	32.4	30.0	55
60				60.5	59.7	58.3	63.8	48.3	44.2	41.3	35.6	30.5	28.4	60
65					52.5	56.4	56.3	44.7	41.0	38.5	33.5	28.9	27.1	65
70					46.6	51.7	50.3	41.8	38.2	35.9	31.8	27.5	25.7	70
75					43.3	46.7	45.2	40.4	35.7	33.6	30.2	26.1	24.5	75
80						42.2	40.7	39.2	33.4	31.5	28.8	24.9	23.3	80
85						38.4	36.8	35.5	31.4	29.4	27.4	23.9	21.9	85
90						34.5	33.6	32.3	30.0	27.7	26.2	22.7	20.4	90
95							30.7	29.4	28.5	26.2	25.1	21.7	19.1	95
100							28.0	27.5	26.6	24.8	23.8	20.9	17.9	100
110								25.1	22.2	22.1	21.6	19.2	15.7	110
120									18.5	19.9	19.8	17.9	14.0	120
130									17.7	17.9	16.9	16.5	12.2	130
140										15.4	15.1	14.9	10.7	140
150											14.0	13.0	9.4	150
160												12.1	8.3	160
170													9.3	170
180														180

\* Special Conditions Or Wire Rope Required  
 (1) Over Rear Only With Swing Lock Engaged

This information is not for crane operation. Operator must refer to the in-cab information for crane operation. Rated lifting capacities shown on fully extended outriggers do not exceed 85% of the tipping loads.

**81,570 lb Counterweight – Fully Extended Outriggers – 360° Rotation**  
**(All Capacities Are Listed In Thousand Pounds)**

Radius (ft)	Boom Length (ft)													Radius (ft)
	43.3 (1)	43.3	57.7	71.9	86.3	100.4	114.8	128.9	143.3	157.5	171.9	186.0	196.9	
9	400.0*													9
10	350.5*	306.0*	264.5*	255.0*	196.5									10
12	318.0*	277.5*	264.5*	255.0*	196.5	162.5								12
14	279.0*	252.0*	253.5*	249.5*	196.5	156.0								14
16	247.0*	226.5	227.0	226.0	196.5	145.5	121.5							16
18	220.5	210.0	210.0	208.5	196.5	136.5	119.5							18
20	197.0	195.5	195.0	194.5	194.0	128.0	117.0	91.3	73.6					20
25	156.5	156.0	156.5	157.5	156.0	111.0	102.0	91.3	73.6	59.3				25
30	128.0	128.0	128.0	129.5	128.0	97.5	95.5	83.8	73.3	59.3	47.6	37.5		30
35			107.5	109.5	108.0	87.1	88.8	75.3	68.3	58.0	47.0	37.5	30.9	35
40			93.0	90.3	88.6	78.0	82.2	68.0	61.7	54.9	45.7	37.4	30.9	40
45			76.7	77.7	76.2	71.9	76.5	62.0	56.5	51.2	42.9	36.3	30.9	45
50				66.4	64.8	66.7	68.2	56.7	51.9	47.9	40.1	34.4	30.9	50
55				56.7	55.6	60.4	59.5	52.2	47.8	44.6	37.7	32.4	30.0	55
60				48.5	51.6	53.2	51.5	48.1	44.2	41.3	35.6	30.5	28.4	60
65					47.3	46.9	45.3	43.7	41.0	38.5	33.5	28.9	27.1	65
70					42.3	41.7	40.1	38.8	37.9	35.9	31.8	27.5	25.7	70
75					37.3	37.2	35.6	34.3	34.3	33.5	30.2	26.1	24.5	75
80						33.4	31.8	32.3	30.5	30.9	28.8	24.9	23.3	80
85						30.2	28.6	29.9	27.1	27.8	27.4	23.9	21.9	85
90						27.0	25.9	27.2	24.4	25.4	25.4	22.7	20.4	90
95							23.4	24.8	22.4	23.9	23.2	21.6	19.1	95
100							21.1	22.6	21.6	22.0	20.9	20.6	17.9	100
110								18.9	19.4	18.2	18.6	17.9	15.7	110
120									16.4	16.2	16.0	14.8	14.0	120
130									14.2	14.4	13.3	12.2	12.2	130
140										12.1	11.2	10.0	10.0	140
150											9.4	8.1	8.1	150
160											7.4	6.4	6.7	160
170												5.1	5.2	170
180													3.8	180

\* Special Conditions Or Wire Rope Required  
 (1) Over Rear Only With Swing Lock Engaged

This information is not for crane operation. Operator must refer to the in-cab information for crane operation. Rated lifting capacities shown on fully extended outriggers do not exceed 85% of the tipping loads.

**55,115 lb Counterweight – Fully Extended Outriggers – 360° Rotation**  
**(All Capacities Are Listed In Thousand Pounds)**

Radius (ft)	Boom Length (ft)													Radius (ft)
	43.3 (1)	43.3	57.7	71.9	86.3	100.4	114.8	128.9	143.3	157.5	171.9	186.0	196.9	
9	400.0*													9
10	350.5*	306.0*	264.5*	255.0*	196.5									10
12	315.5*	277.5*	264.5*	255.0*	196.5	162.5								12
14	267.0*	256.5*	258.0*	252.5*	196.5	156.0								14
16	233.5	233.0	233.5	231.5	196.5	145.5	121.5							16
18	208.5	208.5	208.5	207.0	192.5	136.5	119.5							18
20	186.5	186.5	186.0	187.0	185.5	128.0	117.0	91.3	73.6					20
25	148.0	148.0	147.5	148.5	147.0	111.0	102.0	91.3	73.6	59.3				25
30	120.0	120.4	120.0	122.0	117.5	97.5	95.5	83.8	73.3	59.3	47.6	37.5		30
35			93.8	96.0	91.5	85.2	88.8	75.3	68.3	58.0	47.0	37.5	30.9	35
40			74.8	77.0	75.2	77.2	76.3	67.8	61.7	54.9	45.7	37.4	30.9	40
45			61.2	63.2	64.1	67.1	65.7	59.7	56.5	51.2	42.9	36.3	30.9	45
50				53.0	56.8	57.2	55.6	51.8	49.4	47.9	40.1	34.4	30.9	50
55				47.6	49.5	48.7	47.1	44.7	42.8	42.8	37.7	32.4	30.0	55
60				42.2	42.6	41.9	40.2	39.5	37.3	36.3	35.4	30.5	28.4	60
65					37.1	36.4	35.0	36.1	33.1	32.9	32.3	28.9	27.1	65
70					32.7	32.2	30.7	32.2	28.9	29.1	29.0	27.5	25.7	70
75					28.5	28.5	27.0	28.5	26.7	26.0	25.9	25.3	24.3	75
80						25.3	23.8	25.3	24.8	23.7	23.8	22.5	22.7	80
85						22.4	20.9	22.4	22.8	22.3	22.1	19.8	21.0	85
90						19.6	19.9	20.1	20.8	20.7	20.3	18.0	18.9	90
95							19.1	17.9	18.8	18.9	18.5	16.5	16.9	95
100							18.3	16.4	17.5	17.2	16.6	15.0	15.2	100
110								14.3	15.0	14.4	13.3	12.1	12.2	110
120									12.4	11.5	10.7	9.5	9.5	120
130									10.2	9.3	8.4	7.3	7.3	130
140										7.4	6.6	5.4	5.4	140
150											5.0	4.1	4.1	150
160											3.9	2.4	2.4	160

\* Special Conditions Or Wire Rope Required  
(1) Over Rear Only With Swing Lock Engaged

This information is not for crane operation. Operator must refer to the in-cab information for crane operation. Rated lifting capacities shown on fully extended outriggers do not exceed 85% of the tipping loads.

**28,660 lb Counterweight – Fully Extended Outriggers – 360° Rotation**  
**(All Capacities Are Listed In Thousand Pounds)**

Radius (ft)	Boom Length (ft)												Radius (ft)	
	43.3 (1)	43.3	57.7	71.9	86.3	100.4	114.8	128.9	143.3	157.5	171.9	186.0		196.9
9	400.0*													9
10	348.0*	306.0*	264.5*	255.0*	196.5									10
12	293.5*	276.5*	264.5*	255.0*	196.5	162.5								12
14	252.0*	249.0*	250.0*	245.0*	196.5	156.0								14
16	220.0	220.0	220.0	218.5	196.5	145.5	121.5							16
18	196.5	196.5	196.0	195.0	187.0	136.5	119.5							18
20	175.5	175.5	175.0	176.5	174.0	128.0	117.0	91.3	73.6					20
25	134.5	134.5	134.0	132.5	128.0	111.0	102.0	91.3	73.6	59.3				25
30	96.0	96.0	95.8	98.2	96.4	91.8	94.5	83.8	73.3	59.3	47.6	37.5		30
35			71.2	73.5	74.9	77.9	77.1	70.6	68.0	58.0	47.0	37.5	30.9	35
40			57.1	59.9	60.4	62.7	60.7	55.6	55.3	54.4	45.7	37.4	30.9	40
45			48.2	50.9	51.3	50.9	49.1	46.9	46.6	47.0	42.9	36.3	30.9	45
50				42.6	43.0	42.3	40.5	41.2	38.7	39.2	37.0	34.4	30.9	50
55				35.8	36.2	35.5	33.8	35.6	34.0	32.7	31.8	31.2	29.8	55
60				30.3	30.9	30.1	28.5	30.3	31.1	29.6	28.5	27.2	27.4	60
65					27.9	25.9	26.2	25.9	26.9	26.6	25.5	24.0	24.4	65
70					24.8	22.4	24.4	22.9	23.9	23.7	22.6	20.9	21.4	70
75					21.6	20.6	22.3	20.8	21.3	21.0	19.9	18.3	18.6	75
80						18.8	19.9	18.8	19.2	18.4	17.3	16.0	16.2	80
85						17.3	17.6	17.3	16.9	16.0	14.9	13.8	13.8	85
90						15.8	15.7	15.3	15.0	14.1	13.0	11.9	11.9	90
95							13.9	13.5	13.3	12.4	11.4	10.2	10.3	95
100								12.3	11.9	11.6	10.8	9.9	8.6	100
110									9.4	9.1	8.1	7.4	6.1	110
120										7.0	6.2	5.2	4.0	120
130											5.3	4.4	3.5	130
140												2.9		140

\* Special Conditions Or Wire Rope Required  
(1) Over Rear Only With Swing Lock Engaged

This information is not for crane operation. Operator must refer to the in-cab information for crane operation. Rated lifting capacities shown on fully extended outriggers do not exceed 85% of the tipping loads.

**0 lb Counterweight – Fully Extended Outriggers – 360° Rotation**  
**(All Capacities Are Listed In Thousand Pounds)**

Radius (ft)	Boom Length (ft)									Radius (ft)
	43.3 (1)	43.3	57.7	71.9	86.3	100.4	114.8	128.9	143.3	
10	326.0*	306.0*	264.5*	255.0*	196.5					10
12	274.0*	274.0*	260.0*	252.5*	196.5	162.5				12
14	235.5	235.5	235.0	233.5	196.5	156.0				14
16	205.5	205.5	205.0	206.0	196.5	145.5	121.5			16
18	181.0	181.0	180.5	183.0	179.0	136.5	119.5			18
20	156.0	156.0	156.0	159.5	156.0	127.1	117.0	91.3	54.0	20
25	97.7	95.9	95.6	96.6	94.3	95.3	91.9	87.0	53.7	25
30	66.2	62.0	65.3	69.7	72.4	71.3	68.7	66.3	50.1	30
35			49.6	52.5	53.0	52.1	49.8	49.1	45.9	35
40			38.0	40.4	41.1	40.2	38.4	37.8	38.9	40
45			29.8	32.4	34.3	32.2	33.3	33.0	34.0	45
50				26.4	28.4	28.2	28.7	28.4	28.4	50
55				21.6	23.6	24.1	24.4	24.0	23.6	55
60				17.5	19.7	20.1	20.6	20.1	19.7	60
65					16.5	16.9	17.4	16.9	16.5	65
70					13.9	14.5	14.8	14.5	13.9	70
75					11.4	12.2	12.5	12.2	11.6	75
80						10.2	10.6	10.2	9.7	80
85						8.7	8.9	8.7	8.0	85
90						7.2	7.6	7.2	6.8	90
95							6.3	5.9	5.7	95
100							5.1	4.8	4.6	100
110								3.1	2.9	110

\* Special Conditions Or Wire Rope Required  
 (1) Over Rear Only With Swing Lock Engaged

This information is not for crane operation. Operator must refer to the in-cab information for crane operation. Rated lifting capacities shown on fully extended outriggers do not exceed 85% of the tipping loads.

# Fly Attachment Lift Capacity Charts – Optional

112,435 lb Counterweight – Fully Extended Outriggers – 360° Rotation (All Capacities Are Listed In Thousand Pounds)										
43.3 ft Main Boom Length				186.0 ft Main Boom Length			196.9 ft Main Boom Length			Radius (ft)
Radius (ft)	17.7 ft Offset Fly			17.7 ft Offset Fly			17.7 ft Offset Fly			
	0°	20°	40°	0°	20°	40°	0°	20°	40°	
10	72.8									10
12	68.7	51.4								12
14	65.7	49.3								14
16	63.0	47.9	40.3							16
18	60.0	46.4	39.8							18
20	57.0	45.0	39.4							20
25	51.8	42.6	38.2							25
30	47.3	40.6	37.2							30
35	43.9	38.9	37.0	23.0						35
40	41.2	37.8	37.0	21.9	20.2		20.4			40
45	39.0	37.2		20.9	19.3		19.4	18.0		45
50	37.6			19.9	18.5	17.5	18.5	17.3	16.4	50
55				19.1	17.7	16.9	17.7	16.6	15.8	55
60				18.4	17.1	16.4	17.1	16.0	15.3	60
65				17.5	16.6	15.9	16.4	15.5	14.8	65
70				16.8	16.1	15.4	15.7	15.0	14.3	70
75				16.3	15.6	14.9	15.1	14.5	13.9	75
80				15.7	15.1	14.5	14.6	14.0	13.6	80
85				15.0	14.6	14.1	14.1	13.5	13.2	85
90				14.5	14.1	13.8	13.6	13.1	12.9	90
95				14.1	13.6	13.4	13.1	12.7	12.5	95
100				13.7	13.1	12.9	12.7	12.2	12.0	100
110				12.9	12.4	12.2	12.0	11.6	11.3	110
120				12.2	11.8	11.6	11.3	11.0	10.9	120
130				11.5	11.3	11.1	10.8	10.4	10.4	130
140				11.0	10.8	10.7	10.4	10.1	9.9	140
150				10.6	10.4	10.4	9.9	9.6	9.5	150
160				10.1	9.9	10.1	9.4	9.1	9.1	160
170				8.9	8.9		8.8	8.6	8.6	170
180				7.7	7.6		7.7	7.7		180
190							6.4	6.4		190
200							5.1	5.1		200

This information is not for crane operation. Operator must refer to the in-cab information for crane operation. Rated lifting capacities shown on fully extended outriggers do not exceed 85% of the tipping loads.

112,435 lb Counterweight – Fully Extended Outriggers – 360° Rotation (All Capacities Are Listed In Thousand Pounds)													
196.9 ft Main Boom Length													
Radius (ft)	43.3 ft Offset Fly			63.0 ft Offset Fly			82.7 ft Offset Fly			102.4 ft Offset Fly		122.0 ft Offset Fly	Radius (ft)
	0°	20°	40°	0°	20°	40°	0°	20°	40°	0°	20°	0°	
40	13.9			10.6									40
45	13.9			10.6									45
50	13.9			10.6			7.9			6.2			50
55	13.9			10.6			7.9			6.2		4.5	55
60	13.8	11.7		10.6			7.9			6.2		4.4	60
65	13.3	11.5		10.6			7.9			6.2		4.2	65
70	12.8	11.2	9.6	10.6	9.4		7.9			6.0		4.2	70
75	12.4	10.9	9.4	10.4	9.1		7.9			6.0		4.1	75
80	12.0	10.7	9.2	10.1	8.8		7.9	6.8		5.9		4.0	80
85	11.5	10.4	9.0	9.7	8.6		7.9	6.6		5.7		4.0	85
90	11.1	10.0	9.0	9.4	8.3	7.6	7.9	6.5		5.6		3.8	90
95	10.8	9.7	8.9	9.2	8.1	7.4	7.7	6.4		5.5	4.4	3.7	95
100	10.5	9.4	8.8	8.9	7.8	7.2	7.4	6.3	5.5	5.5	4.4	3.7	100
110	10.0	9.1	8.4	8.4	7.3	6.9	7.1	6.0	5.3	5.1	4.2	3.5	110
120	9.4	8.5	8.1	7.9	7.0	6.6	6.6	5.9	5.2	5.0	4.0	3.3	120
130	8.9	8.2	7.8	7.5	6.7	6.2	6.2	5.6	5.1	4.9	4.0	3.1	130
140	8.4	7.9	7.6	7.2	6.3	6.0	5.9	5.2	4.9	4.7	3.8	3.1	140
150	8.0	7.5	7.3	6.9	6.1	5.9	5.6	5.0	4.8	4.5	3.7	3.0	150
160	7.6	7.2	7.0	6.5	5.9	5.6	5.4	4.8	4.6	4.4	3.5	2.8	160
170	7.3	6.9	6.8	6.2	5.7	5.3	5.1	4.6	4.4	4.2	3.3	2.7	170
180	7.0	6.7	6.5	5.9	5.4	5.1	4.9	4.5	4.3	4.0	3.1	2.6	180
190	6.6	6.5	6.3	5.6	5.2	5.1	4.7	4.3	4.1	3.9	3.1	2.5	190
200	6.1	6.1	5.9	5.4	5.0	5.0	4.5	4.1	3.9	3.7	3.0	2.4	200
210	5.1	5.3	5.1	5.1	4.8	4.8	4.2	3.7	3.7	3.5	2.9	2.4	210
220	4.2	4.3	3.6	4.6	4.7	4.7	3.9	3.4	3.6	3.4	2.7	2.3	220
230				3.7	3.8	3.7	3.5	3.1	3.4	3.2	2.6		230
240							3.1	2.8	3.1	3.0	2.6		240
250							2.4	2.6	2.4	2.6	2.4		250

This information is not for crane operation. Operator must refer to the in-cab information for crane operation. Rated lift capacities shown on fully extended outriggers do not exceed 85% of the tipping loads.

112,435 lb Counterweight – Fully Extended Outriggers – 360° Rotation (All Capacities Are Listed In Thousand Pounds)															
186.0 ft Main Boom Length															
Radius (ft)	43.3 ft Offset Fly			63.0 ft Offset Fly			82.7 ft Offset Fly			102.4 ft Offset Fly			122.0 ft Offset Fly		Radius (ft)
	0°	20°	40°	0°	20°	40°	0°	20°	40°	0°	20°	40°	0°	20°	
40	16.5			12.3			9.3								40
45	16.5			12.3			9.3								45
50	16.0			12.3			9.3			6.9					50
55	15.3	12.2		12.3			9.3			6.8			4.8		55
60	14.7	11.8		12.3			9.3			6.6			4.6		60
65	14.2	11.5		11.9			9.3			6.4			4.4		65
70	13.7	11.3	9.6	11.5	9.8		9.0			6.4			4.4		70
75	13.2	11.1	9.4	11.1	9.5		8.7			6.3			4.3		75
80	12.7	10.8	9.3	10.7	9.2		8.6	7.0		6.1			4.2		80
85	12.4	10.6	9.3	10.4	9.0		8.4	6.8		6.0			4.2		85
90	11.9	10.4	9.1	10.0	8.7	8.0	8.2	6.7		5.8			4.0		90
95	11.5	10.2	8.9	9.7	8.5	7.8	8.1	6.5		5.7	4.5		3.9		95
100	11.1	9.9	8.8	9.4	8.3	7.7	7.9	6.4	5.5	5.7	4.4		3.7		100
110	10.5	9.5	8.6	8.9	7.8	7.2	7.4	6.2	5.3	5.3	4.2		3.6	2.9	110
120	10.0	9.0	8.4	8.3	7.4	7.0	7.0	6.0	5.2	5.1	4.1	3.7	3.5	2.6	120
130	9.3	8.6	8.2	8.0	7.1	6.7	6.7	5.8	5.1	4.9	4.0	3.5	3.3	2.5	130
140	9.0	8.3	8.0	7.5	6.8	6.3	6.3	5.4	4.9	4.7	3.8	3.4	3.2	2.4	140
150	8.5	8.0	7.7	7.2	6.4	6.1	6.0	5.2	4.8	4.5	3.7	3.3	3.0	2.3	150
160	8.1	7.7	7.5	7.0	6.1	5.9	5.6	5.0	4.6	4.4	3.5	3.3	2.8	2.2	160
170	7.7	7.5	7.3	6.6	6.0	5.7	5.3	4.9	4.6	4.2	3.5	3.1	2.7	2.2	170
180	7.6	7.2	7.1	6.3	5.8	5.6	5.1	4.7	4.5	4.0	3.4	3.1	2.5		180
190	7.2	6.8	6.9	6.1	5.6	5.4	5.0	4.5	4.3	3.9	3.2	3.0	2.4		190
200	6.5	6.3	6.4	5.8	5.5	5.3	4.8	4.4	4.1	3.7	3.1	2.9	2.4		200
210	5.3	5.3	4.8	5.5	5.3	5.3	4.6	4.2	4.0	3.5	3.1	2.9	2.2		210
220				4.8	4.8	4.6	4.5	4.0	4.0	3.5	2.9	2.9	2.2		220
230				3.9	3.8		4.1	3.9	3.9	3.4	2.9	2.9			230
240							3.4	3.4		3.2	2.9	2.9			240
250							2.6	2.6		2.8	2.9	2.9			250

This information is not for crane operation. Operator must refer to the in-cab information for crane operation. Rated lifting capacities shown on fully extended outriggers do not exceed 85% of the tipping loads.



81,570 lb Counterweight – Fully Extended Outriggers – 360° Rotation (All Capacities Are Listed In Thousand Pounds)										
43.3 ft Main Boom Length				186.0 ft Main Boom Length			196.9 ft Main Boom Length			Radius (ft)
Radius (ft)	17.7 ft Offset Fly			17.7 ft Offset Fly			17.7 ft Offset Fly			
	0°	20°	40°	0°	20°	40°	0°	20°	40°	
10	72.8									10
12	68.7	51.4								12
14	65.7	49.3								14
16	63.0	47.9	40.3							16
18	60.0	46.4	39.8							18
20	57.0	45.0	39.4							20
25	51.8	42.6	38.2							25
30	47.3	40.6	37.2							30
35	43.9	38.9	37.0	23.0						35
40	41.2	37.8	37.0	21.9	20.2		20.4			40
45	39.0	37.2		20.9	19.3		19.4	18.0		45
50	37.6			19.9	18.5	17.5	18.5	17.3	16.4	50
55				19.1	17.7	16.9	17.7	16.6	15.8	55
60				18.4	17.1	16.4	17.1	16.0	15.3	60
65				17.5	16.6	15.9	16.4	15.5	14.8	65
70				16.8	16.1	15.4	15.7	15.0	14.3	70
75				16.3	15.6	14.9	15.1	14.5	13.9	75
80				15.7	15.1	14.5	14.6	14.0	13.6	80
85				15.0	14.6	14.1	14.1	13.5	13.2	85
90				14.5	14.1	13.8	13.6	13.1	12.9	90
95				14.1	13.6	13.4	13.1	12.7	12.5	95
100				13.7	13.1	12.9	12.7	12.2	12.0	100
110				12.9	12.4	12.2	12.0	11.6	11.3	110
120				12.2	11.8	11.6	11.3	11.0	10.9	120
130				11.5	11.3	11.1	10.8	10.4	10.4	130
140				10.0	10.1	10.1	9.8	9.8	9.9	140
150				8.3	8.5	8.7	8.2	8.5	8.7	150
160				6.7	6.9	6.8	6.5	6.9	6.9	160
170				5.2	5.2		5.2	5.2	5.2	170
180				3.8	3.8		3.8	3.8		180

This information is not for crane operation. Operator must refer to the in-cab information for crane operation. Rated lifting capacities shown on fully extended outriggers do not exceed 85% of the tipping loads.

81,570 lb Counterweight – Fully Extended Outriggers – 360° Rotation (All Capacities Are Listed In Thousand Pounds)													
196.9 ft Main Boom Length													
Radius (ft)	43.3 ft Offset Fly			63.0 ft Offset Fly			82.7 ft Offset Fly			102.4 ft Offset Fly		122.0 ft Offset Fly	Radius (ft)
	0°	20°	40°	0°	20°	40°	0°	20°	40°	0°	20°	0°	
40	13.9			10.6									40
45	13.9			10.6									45
50	13.9			10.6			7.9			6.2			50
55	13.9			10.6			7.9			6.2		4.5	55
60	13.8	11.7		10.6			7.9			6.2		4.4	60
65	13.3	11.5		10.6			7.9			6.2		4.2	65
70	12.8	11.2	9.6	10.6	9.4		7.9			6.0		4.2	70
75	12.4	10.9	9.4	10.4	9.1		7.9			6.0		4.1	75
80	12.0	10.7	9.2	10.1	8.8		7.9	6.8		5.9		4.0	80
85	11.5	10.4	9.0	9.7	8.6		7.9	6.6		5.7		4.0	85
90	11.1	10.0	9.0	9.4	8.3	7.6	7.9	6.5		5.6		3.8	90
95	10.8	9.7	8.9	9.2	8.1	7.4	7.7	6.4		5.5	4.4	3.7	95
100	10.5	9.4	8.8	8.9	7.8	7.2	7.4	6.3	5.5	5.5	4.4	3.7	100
110	10.0	9.1	8.4	8.4	7.3	6.9	7.1	6.0	5.3	5.1	4.2	3.5	110
120	9.4	8.5	8.1	7.9	7.0	6.6	6.6	5.9	5.2	5.0	4.0	3.3	120
130	8.9	8.2	7.8	7.5	6.7	6.2	6.2	5.6	5.1	4.9	4.0	3.1	130
140	8.4	7.9	7.6	7.2	6.3	6.0	5.9	5.2	4.9	4.7	3.8	3.1	140
150	8.0	7.5	7.3	6.9	6.1	5.9	5.6	5.0	4.8	4.5	3.7	3.0	150
160	7.4	7.2	7.0	6.5	5.9	5.6	5.4	4.8	4.6	4.4	3.5	2.8	160
170	6.2	6.9	6.8	6.2	5.7	5.3	5.1	4.6	4.4	4.2	3.3	2.7	170
180	4.9	5.4	5.6	5.2	5.4	5.1	4.9	4.5	4.3	4.0	3.1	2.6	180
190	3.8	4.1	4.2	4.1	4.8	4.9	4.4	4.3	4.1	3.9	3.1	2.5	190
200	2.8	2.9	2.9	2.9	3.9	4.2	3.7	4.0	3.9	3.5	3.0	2.4	200
210					2.9	2.9	2.6	3.3	3.7	2.6	2.9	2.4	210
220								2.7			2.7		220

This information is not for crane operation. Operator must refer to the in-cab information for crane operation. Rated lifting capacities shown on fully extended outriggers do not exceed 85% of the tipping loads.

**81,570 lb Counterweight – Fully Extended Outriggers – 360° Rotation**  
**(All Capacities Are Listed In Thousand Pounds)**

**186.0 ft Main Boom Length**

Radius (ft)	43.3 ft Offset Fly			63.0 ft Offset Fly			82.7 ft Offset Fly			102.4 ft Offset Fly			122.0 ft Offset Fly		Radius (ft)
	0°	20°	40°	0°	20°	40°	0°	20°	40°	0°	20°	40°	0°	20°	
40	16.5			12.3			9.3								40
45	16.5			12.3			9.3								45
50	16.0			12.3			9.3			6.9					50
55	15.3	12.2		12.3			9.3			6.8			4.8		55
60	14.7	11.8		12.3			9.3			6.6			4.6		60
65	14.2	11.5		11.9			9.3			6.4			4.4		65
70	13.7	11.3	9.6	11.5	9.8		9.0			6.4			4.4		70
75	13.2	11.1	9.4	11.1	9.5		8.7			6.3			4.3		75
80	12.7	10.8	9.3	10.7	9.2		8.6	7.0		6.1			4.2		80
85	12.4	10.6	9.3	10.4	9.0		8.4	6.8		6.0			4.2		85
90	11.9	10.4	9.1	10.0	8.7	8.0	8.2	6.7		5.8			4.0		90
95	11.5	10.2	8.9	9.7	8.5	7.8	8.1	6.5		5.7	4.5		3.9		95
100	11.1	9.9	8.8	9.4	8.3	7.7	7.9	6.4	5.5	5.7	4.4		3.7		100
110	10.5	9.5	8.6	8.9	7.8	7.2	7.4	6.2	5.3	5.3	4.2		3.6	2.9	110
120	10.0	9.0	8.4	8.3	7.4	7.0	7.0	6.0	5.2	5.1	4.1	3.7	3.5	2.6	120
130	9.3	8.6	8.2	8.0	7.1	6.7	6.7	5.8	5.1	4.9	4.0	3.5	3.3	2.5	130
140	9.0	8.3	8.0	7.5	6.8	6.3	6.3	5.4	4.9	4.7	3.8	3.4	3.2	2.4	140
150	8.4	8.0	7.7	7.2	6.4	6.1	6.0	5.2	4.8	4.5	3.7	3.3	3.0	2.3	150
160	7.6	7.5	7.4	7.0	6.1	5.9	5.6	5.0	4.6	4.4	3.5	3.3	2.8	2.2	160
170	6.5	6.9	7.1	6.6	6.0	5.7	5.3	4.9	4.6	4.2	3.5	3.1	2.7	2.2	170
180	5.1	5.6	5.6	5.5	5.8	5.6	5.1	4.7	4.5	4.0	3.4	3.1	2.5		180
190	3.9	4.2	4.1	4.4	5.1	5.0	4.5	4.5	4.3	3.9	3.2	3.0	2.4		190
200		2.9	2.6	3.4	4.0	4.0	3.7	4.3	4.1	3.5	3.1	2.9	2.4		200
210				2.4	2.9	2.6	2.6	3.7	4.0	2.9	3.1	2.9	2.2		210
220											2.9	2.9			220

This information is not for crane operation. Operator must refer to the in-cab information for crane operation. Rated lifting capacities shown on fully extended outriggers do not exceed 85% of the tipping loads.

55,115 lb Counterweight – Fully Extended Outriggers – 360° Rotation (All Capacities Are Listed In Thousand Pounds)										
43.3 ft Main Boom Length				186.0 ft Main Boom Length			196.9 ft Main Boom Length			Radius (ft)
Radius (ft)	17.7 ft Offset Fly			17.7 ft Offset Fly			17.7 ft Offset Fly			
	0°	20°	40°	0°	20°	40°	0°	20°	40°	
10	72.8									10
12	68.7	51.4								12
14	65.7	49.3								14
16	63.0	47.9	40.3							16
18	60.0	46.4	39.8							18
20	57.0	45.0	39.4							20
25	51.8	42.6	38.2							25
30	47.3	40.6	37.2							30
35	43.9	38.9	37.0	23.0						35
40	41.2	37.8	37.0	21.9	20.2		20.4			40
45	39.0	37.2		20.9	19.3		19.4	18.0		45
50	37.6			19.9	18.5	17.5	18.5	17.3	16.4	50
55				19.1	17.7	16.9	17.7	16.6	15.8	55
60				18.4	17.1	16.4	17.1	16.0	15.3	60
65				17.5	16.6	15.9	16.4	15.5	14.8	65
70				16.8	16.1	15.4	15.7	15.0	14.3	70
75				16.3	15.6	14.9	15.1	14.5	13.9	75
80				15.7	15.1	14.5	14.6	14.0	13.6	80
85				15.0	14.6	14.1	14.1	13.5	13.2	85
90				14.5	14.1	13.8	13.6	13.1	12.9	90
95				14.1	13.6	13.4	13.1	12.7	12.5	95
100				13.7	13.1	12.9	12.7	12.2	12.0	100
110				12.0	12.4	12.2	11.8	11.6	11.3	110
120				9.5	10.0	10.5	9.5	10.0	10.5	120
130				7.3	7.8	8.0	7.3	7.8	8.0	130
140				5.6	5.9	6.1	5.6	5.9	6.1	140
150				4.0	4.2	4.3	4.0	4.2	4.4	150

This information is not for crane operation. Operator must refer to the in-cab information for crane operation. Rated lifting capacities shown on fully extended outriggers do not exceed 85% of the tipping loads.

**55,115 lb Counterweight – Fully Extended Outriggers – 360° Rotation**  
**(All Capacities Are Listed In Thousand Pounds)**

**196.9 ft Main Boom Length**

Radius (ft)	43.3 ft Offset Fly			63.0 ft Offset Fly			82.7 ft Offset Fly			102.4 ft Offset Fly		122.0 ft Offset Fly	Radius (ft)
	0°	20°	40°	0°	20°	40°	0°	20°	40°	0°	20°	0°	
40	13.9			10.6									40
45	13.9			10.6									45
50	13.9			10.6			7.9			6.2			50
55	13.9			10.6			7.9			6.2		4.5	55
60	13.8	11.7		10.6			7.9			6.2		4.4	60
65	13.3	11.5		10.6			7.9			6.2		4.2	65
70	12.8	11.2	9.6	10.6	9.4		7.9			6.0		4.2	70
75	12.4	10.9	9.4	10.4	9.1		7.9			6.0		4.1	75
80	12.0	10.7	9.2	10.1	8.8		7.9	6.8		5.9		4.0	80
85	11.5	10.4	9.0	9.7	8.6		7.9	6.6		5.7		4.0	85
90	11.1	10.0	9.0	9.4	8.3	7.6	7.9	6.5		5.6		3.8	90
95	10.8	9.7	8.9	9.2	8.1	7.4	7.7	6.4		5.5	4.4	3.7	95
100	10.5	9.4	8.8	8.9	7.8	7.2	7.4	6.3	5.5	5.5	4.4	3.7	100
110	10.0	9.1	8.4	8.4	7.3	6.9	7.1	6.0	5.3	5.1	4.2	3.5	110
120	9.4	8.5	8.1	7.9	7.0	6.6	6.6	5.9	5.2	5.0	4.0	3.3	120
130	8.3	8.2	7.8	7.5	6.7	6.2	6.2	5.6	5.1	4.9	4.0	3.1	130
140	6.5	7.4	7.6	6.8	6.3	6.0	5.9	5.2	4.9	4.7	3.8	3.1	140
150	5.1	6.1	6.5	5.5	6.0	5.9	5.4	5.0	4.8	4.5	3.7	3.0	150
160	3.9	4.5	4.9	4.1	5.4	5.5	4.5	4.8	4.6	4.2	3.5	2.8	160
170	2.5	3.2	3.4	2.9	4.0	4.7	3.2	4.6	4.4	3.4	3.3	2.7	170
180					2.9	3.4		3.5	4.1		3.1		180
190								3.2			2.8		190

This information is not for crane operation. Operator must refer to the in-cab information for crane operation. Rated lifting capacities shown on fully extended outriggers do not exceed 85% of the tipping loads.

55,115 lb Counterweight – Fully Extended Outriggers – 360° Rotation (All Capacities Are Listed In Thousand Pounds)															
186.0 ft Main Boom Length															
Radius (ft)	43.3 ft Offset Fly			63.0 ft Offset Fly			82.7 ft Offset Fly			102.4 ft Offset Fly			122.0 ft Offset Fly		Radius (ft)
	0°	20°	40°	0°	20°	40°	0°	20°	40°	0°	20°	40°	0°	20°	
40	16.5			12.3			9.3								40
45	16.5			12.3			9.3								45
50	16.0			12.3			9.3			6.9					50
55	15.3	12.2		12.3			9.3			6.8			4.8		55
60	14.7	11.8		12.3			9.3			6.6			4.6		60
65	14.2	11.5		11.9			9.3			6.4			4.4		65
70	13.7	11.3	9.6	11.5	9.8		9.0			6.4			4.4		70
75	13.2	11.1	9.4	11.1	9.5		8.7			6.3			4.3		75
80	12.7	10.8	9.3	10.7	9.2		8.6	7.0		6.1			4.2		80
85	12.4	10.6	9.3	10.4	9.0		8.4	6.8		6.0			4.2		85
90	11.9	10.4	9.1	10.0	8.7	8.0	8.2	6.7		5.8			4.0		90
95	11.5	10.2	8.9	9.7	8.5	7.8	8.1	6.5		5.7	4.5		3.9		95
100	11.1	9.9	8.8	9.4	8.3	7.7	7.9	6.4	5.5	5.7	4.4		3.7		100
110	10.5	9.5	8.6	8.9	7.8	7.2	7.4	6.2	5.3	5.3	4.2		3.6	2.9	110
120	10.0	9.0	8.4	8.3	7.4	7.0	7.0	6.0	5.2	5.1	4.1	3.7	3.5	2.6	120
130	8.8	8.6	8.2	8.0	7.1	6.7	6.7	5.8	5.1	4.9	4.0	3.5	3.3	2.5	130
140	7.0	7.6	7.7	7.1	6.8	6.3	6.3	5.4	4.9	4.7	3.8	3.4	3.2	2.4	140
150	5.3	6.1	6.5	5.8	6.2	6.1	5.7	5.2	4.8	4.5	3.7	3.3	3.0	2.3	150
160	3.9	4.5	4.9	4.3	5.4	5.7	4.7	5.0	4.6	4.3	3.5	3.3	2.8	2.2	160
170	2.5	3.2	3.4	2.9	4.3	4.7	3.4	4.9	4.6	3.8	3.5	3.1	2.7	2.2	170
180					2.9	3.4		3.6	4.2		3.4	3.1	2.5		180
190									3.2		2.9	3.0			190
200												2.8			200

This information is not for crane operation. Operator must refer to the in-cab information for crane operation. Rated lifting capacities shown on fully extended outriggers do not exceed 85% of the tipping loads.

28,660 lb Counterweight – Fully Extended Outriggers – 360° Rotation (All Capacities Are Listed In Thousand Pounds)																	
43.3 ft Main Boom				186.0 ft Main Boom						196.9 ft Main Boom							
Radius (ft)	17.7 ft Offset Fly			17.7 ft Offset Fly			43.3 ft Offset Fly			17.7 ft Offset Fly			43.3 ft Offset Fly				Radius (ft)
	0°	20°	40°	0°	20°	40°	0°	20°	40°	0°	20°	40°	0°	20°	40°		
10	72.8															10	
12	68.7	51.4														12	
14	65.7	49.3														14	
16	63.0	47.9	40.3													16	
18	60.0	46.4	39.8													18	
20	57.0	45.0	39.4													20	
25	51.8	42.6	38.2													25	
30	47.3	40.6	37.2													30	
35	43.9	38.9	37.0	23.0												35	
40	41.2	37.8	37.0	21.9	20.2		16.5			20.4			13.9			40	
45	39.0	37.2		20.9	19.3		16.5			19.4	18.0		13.9			45	
50	37.6			19.9	18.5	17.5	16.0			18.5	17.3	16.4	13.9			50	
55				19.1	17.7	16.9	15.3	12.2		17.7	16.6	15.8	13.9			55	
60				18.4	17.1	16.4	14.7	11.8		17.1	16.0	15.3	13.8	11.7		60	
65				17.5	16.6	15.9	14.2	11.5		16.4	15.5	14.8	13.3	11.5		65	
70				16.8	16.1	15.4	13.7	11.3	9.6	15.7	15.0	14.3	12.8	11.2	9.6	70	
75				16.3	15.6	14.9	13.2	11.1	9.4	15.1	14.5	13.9	12.4	10.9	9.4	75	
80				15.5	15.1	14.5	12.7	10.8	9.3	14.6	14.0	13.6	12.0	10.7	9.2	80	
85				14.0	14.6	14.1	12.4	10.6	9.3	13.9	13.5	13.2	11.5	10.4	9.0	85	
90				12.2	12.8	13.2	11.9	10.4	9.1	12.2	12.5	12.9	11.1	10.0	9.0	90	
95				10.4	11.1	11.6	11.2	10.2	8.9	10.4	11.1	11.6	10.7	9.7	8.9	95	
100				8.8	9.4	9.9	10.2	9.9	8.8	8.8	9.4	9.9	10.0	9.4	8.8	100	
110				6.1	6.9	7.3	7.5	9.0	8.6	6.1	6.9	7.3	7.5	8.8	8.4	110	
120				4.0	4.7	5.0	5.4	6.7	7.8	4.0	4.7	5.0	5.2	6.7	7.6	120	
130					2.9	3.1	3.6	4.8	5.6		2.9	3.1	3.5	4.8	5.5	130	
140								3.3	3.8					3.2	3.8	140	

This information is not for crane operation. Operator must refer to the in-cab information for crane operation. Rated lifting capacities shown on fully extended outriggers do not exceed 85% of the tipping loads.

**Link-Belt Construction Equipment Company** Lexington, Kentucky    [www.linkbelt.com](http://www.linkbelt.com)

®Link-Belt is a registered trademark. Copyright 2008. We are constantly improving our products and therefore reserve the right to change designs and specifications.